

ELEVATING EXCELLENCE  
◀ IN AGRICULTURE ▶



# 2025 SPONSORSHIP OPPORTUNITIES

**DENVER** | MARCH 2-4, 2025  
COLORADO CONVENTION CENTER

*All opportunities current as of 8/23/24*



## Sponsorship Increases Visibility and Value for Your Company Among Thousands of America's Best Farmers!

Join Commodity Classic in Denver in 2025 as we're ***Elevating Excellence in Agriculture!*** As a sponsor, your brand can be highly visible throughout the venue and in the materials and media that farmers use during the entire event. Commodity Classic sponsor opportunities expand your presence and run the gamut from events to graphics, from meals to multimedia. You can be where farmers walk, talk, eat, and relax.

As you review these offerings, you'll discover unique and effective opportunities to promote your brand and your support for agriculture. Always feel free to contact us if you have any questions or want to discuss any ideas you have for sponsorship opportunities that might not be listed here.

### Important Notes:

- 2024 sponsors have the first right of refusal for some items listed.
- Some sponsorships require printing and installation which is indicated in the description of the item. These costs are not included in the calculation of exhibitor sponsorship level.

To commit to a sponsorship, please reach out to Commodity Classic staff (sponsorship contacts are listed below).

*Please note that a sponsorship is not final until a contract is issued and signed.*

We look forward to ***Elevating Excellence in Agriculture*** with you at the 2025 Commodity Classic in Denver!

## CONTACTS

Abby Podkul  
Director, Meetings & Conventions  
American Soybean Association  
O: 314-754-1345 C: 314-517-5971  
apodkul@soy.org

Maureen Feck  
Commodity Classic Show Director  
C: 773-329-7561  
Feck@commodityclassic.com



# TABLE OF CONTENTS

## Attendee Services & Events

Beverage Greetings.....	5	Hotel Shuttles .....	10
Branded Email Marketing.....	5	Luggage & Coat Check with Luggage Tags.....	10
Chair Massages .....	5	Media Room & Media Reception .....	10
Closing Reception.....	6	Mobile App .....	11
Convention Badge Lanyards .....	6	Pancake Brunch.....	11
Convention Center Signage & Branding.....	6	Program Booklet – Back Cover Ad .....	11
Courtesy Rides – Convention Center Lobby .....	6	Program Booklet – Interior Ad .....	12
Courtesy Rides – Trade Show .....	7	Registration Brochure .....	12
Device Charging Seating Areas.....	7	Registration Tote Bags.....	12
Education: Commodity Classic Main Stage .....	8	Reusable Water Bottles .....	12
Education: Learning Centers, Opening Learning Center, and Early Riser Sessions.....	8	Spin It to Win It .....	12
Education: Mini What’s New Sessions.....	8	Trade Show Grand Opening & Daily Sponsor (Day 1: Sunday).....	13
Education: What’s New Sessions.....	8	Trade Show & Lunch Daily Sponsor (Day 2: Monday).....	13
First-Time Attendee Reception .....	9	Trade Show & Lunch Daily Sponsor (Day 3: Tuesday) .....	14
General Session.....	9	Video Monitors Advertising .....	14
General Support.....	9	Welcome Reception .....	15
Hotel Branding & Signage.....	9	WiFi.....	15
Hotel Room Key Cards .....	10	Worship Service .....	15

## Association-Specific Events

ASA Awards Celebration .....	16
NCGA Winners Circle Celebration .....	16

## Convention Center Floor Plan ..... 19-20

## Signage & Branding Opportunities

Convention Center Artwork	
Deadlines & Production Guidelines.....	21



## SIGNAGE & BRANDING OPPORTUNITIES

### Convention Center Branding Opportunities..... 18

- #1: Atrium Window Banner
- #2: Atrium Window Banner
- #3: Atrium Window Banner
- #4: Atrium Window Banner
- #5: Atrium Lobby A/F Escalator Glass Cling
- #6: Atrium Lobby A Railing Banner
- #7: Atrium Lobby A Staircase Glass Cling
- #8: Atrium Lobby A Building Entry Doors
- #9: Atrium Lobby F Railing Banner
- #10: Lobby A Wall Banner
- #11: Device Charging Seating Area - Lobby A
- #12: Lobby A Massage Area
- #13: Lobby A Column Wrap
- #14: Lobby A Column Wrap
- #15: Lobby A Column Wrap
- #16: Lobby A Column Wrap
- #17: Lobby A Column Wrap
- #18: Lobby A Column Wrap
- #19: Lobby A Café Glass Clings
- #20: Grand Concourse Banner & Column Wrap
- #21: Grand Concourse Banner & Column Wrap
- #22: Grand Concourse Banner & Column Wrap
- #23: Device Charging Seating Area – Grand Concourse by 400 Rooms
- #24: Device Charging Seating Area – Grand Concourse Blue Wall
- #25: Grand Concourse Railing Glass Clings
- #26: Stair Landing Clings from Grand Concourse to Mile High Ballroom
- #27: Grand Concourse Railing Glass Clings
- #28: Grand Concourse Railing Glass Clings
- #29: Device Charging Seating Area - Grand Concourse by 500 Rooms
- #30: Grand Concourse Banner & Column Wrap
- #31: Grand Concourse Banner & Column Wrap
- #32: Device Charging Seating Area - Mile High Ballroom Foyer
- #33: Mile High Ballroom Foyer Banner
- #34: Lobby D Elevator Door Clings
- #35: Lobby C/D Column Wrap
- #36: Lobby C/D Column Wrap
- #37: Lobby C/D Column Wrap
- #38: Lobby C/D Column Wrap
- #39: Bluebird Stair Clings
- #40: Device Charging Seating Area - Upper Lobby D
- #41: Glass Railing Clings
- #42: Lobby B Registration Door Clings
- #43: Lobby B Registration Wall Cling
- #44: Lobby B Registration Wall Cling

### Hyatt Regency Denver Branding Opportunities ..... 66

- Main Lobby Round Column
- Main Lobby Floor Cling
- Elevator Doors
- Escalators – Lobby to 3rd Floor
- Windows Between Lobby Escalators and Assembly Lounge
- California Street Entrance Push Doors
- Hotel Restaurant “Former Saint” Windows
- Hotel Restaurant “Former Saint” Exterior Columns

### Embassy Suites Branding Opportunities..... 75

- #1: Embassy Suites Entrance
- #2: Embassy Suites Elevator Doors – Ground Floor Lobby
- #3: Embassy Suites Elevator Doors – Level 4/Main Lobby

### Hilton Denver Branding Opportunities ..... 79

Please contact Abby Podkul for details:

O: 314-754-1345 C: 314-517-5971

apodkul@soy.org



## Beverage Greetings..... \$12,000

Offered exclusively to one sponsor. Choose your day! Monday, March 3 or Tuesday, March 4; choose one beverage to offer. Greet attendees and put a smile on their faces in the Convention Center lobby with a delicious cup of coffee or orange juice as they enter the building on the morning of your selected day. Sponsorship fee includes 50 gallons of your selected beverage, promotion of the event in show materials, recognition of your company as the sponsor, and signage provided by Commodity Classic at the distribution point. Beverage will be offered to attendees for one hour or until the initial order of 50 gallons runs out. The distribution location will be at a prominent entry point into the building. Sponsor is welcome to greet attendees in person and may provide company-branded cups and/or napkins and branded company attire to the catering staff.



**Commitment deadline: December 20, 2024**

## Branded Email Marketing *NEW! for 2025* ..... \$9,500

Feature your banner advertising on four Commodity Classic eblasts to be sent in January and February 2025, just ahead of the show. These eblasts serve to communicate show management messages such as announcement of the General Session keynote speaker, details about the schedule of events, and sharing useful 'know before you go' tips. The eblasts will be sent to over 28,000 Commodity Classic contacts including current registrants and those who have opted in to Commodity Classic's general information email list. Banner ad size is 1200 x 300 pixels and will be located below Commodity Classic show messaging. Your company's banner ad will be the only sponsor ad included on each eblast, and your ad may link to whatever URL you wish. Sponsorship fee includes four eblasts sent in January and February 2025.

**Commitment deadline: December 13, 2024 • Artwork deadline: December 20, 2024**

## Chair Massages..... \$9,500

Be a hero to attendees as they enjoy complimentary seated, back and shoulder massages sponsored by your company. The Commodity Classic Massage Area, located in the Convention Center Lobby A, is an opportunity to associate your brand with rest and relaxation. Certified massage therapists will provide 10-minute upper body massages in specially designed chairs during designated hours on Sunday, Monday, and Tuesday. Sponsorship fee includes certified massage therapists and all equipment. Sponsor may provide a pull-up banner with company messaging



and company handouts, and your company will be recognized in event materials and onsite signage as the sponsor of this complimentary service. Sponsor may choose to wrap the column that flanks this space (additional fee for printing & installation of your graphics on the column). See Convention Center Opportunity #12 in this booklet for location details.

**Commitment deadline: December 20, 2024**



**Closing Reception *NEW! for 2025* ..... \$67,000**



The Closing Reception, scheduled for Tuesday, March 4 from 5:30-7:00 p.m., is a new event in 2025. This fun social event will immediately follow the afternoon General Session. Don't miss this exclusive chance to help attendees kick back, mingle, and wrap up their Commodity Classic experience on a high note. Enjoy light bites, refreshing beverages, casual conversation, and camaraderie in a friendly, relaxed atmosphere. Celebrate the connections made and knowledge gained over the past few days. Cheers to a great week! As the exclusive sponsor of this event, showcase your brand and position your company as a valuable industry partner. Commodity Classic will provide light food & beverages and will promote your company as the exclusive sponsor of the event. The Closing Reception sponsor is encouraged to provide fun activities, activations, and/or entertainment to build out the event.

**Convention Badge Lanyards\* ..... \$30,000**

Lanyards for convention badges imprinted with your company logo or name will be distributed onsite to all registrants. This is a great way to promote your company name to Commodity Classic attendees throughout the show.

**Commitment deadline: September 15, 2024**

**Convention Center Signage & Branding ..... Pricing varies per branding opportunity**

Signage and branding opportunities at the Colorado Convention Center include window clings, banners, column wraps, elevator doors, floor clings, and more! See the back half of this book for pricing and details about each opportunity.

**Commitment deadline: January 10, 2025 • Artwork deadline: February 5, 2025**

**Courtesy Rides – Convention Center Lobby\* *NEW! for 2025* ..... \$12,500**

Provide attendees complimentary rides on golf carts that travel back and forth along the convention center's Grand Concourse during designated hours, from Lobby A/F at one end of the building (by the iconic Blue Bear mascot entrance to the Lobby C/D end of the building (by Bellco Theater and the escalator and elevator up to Bluebird Ballroom where the Pancake Brunch, Welcome Reception, meals, and the Closing Reception will take place). This service will save attendees time and steps when heading to events at either end of the building. And even if attendees choose not to grab a ride, they'll see your company's branding as the golf carts roll past them in this busy corridor.

Included with this sponsorship is one 6-passenger golf cart, a driver for the golf cart, one roof sign (2'x 6'), and one hood sign (18"x 18") on the golf cart with your company's graphics. Drivers may wear company-branded attire and hand out company items to riders. Also, your company representatives may drive the golf cart if you prefer. Two signs promoting the complimentary shuttle with your company's name or logo will be placed at each end of the Grand Concourse, the convention center's central corridor. Your company's name will be included in event materials promoting this complimentary service.

**Commitment deadline: December 20, 2024**

\*2024 sponsors have the first right of refusal for some items listed.



**Courtesy Rides – Trade Show\* ..... \$12,500**

Provide attendees complimentary rides on golf carts that travel along the trade show’s main aisles during trade show hours. Your company’s name or logo will be included in event materials promoting this complimentary service. Included with this sponsorship are two 6-passenger golf carts, drivers for the golf carts, one roof sign (2’x 6’) and one hood sign (18”x 18”) on both golf carts with your company’s graphics. Drivers may wear company-branded attire and hand out company items to riders. Also, your company representatives may drive the golf carts if you prefer.

Two “shuttle stop” signs with your company’s name or logo will be placed at each end of the cart path aisle in the trade show. If your company’s booth is located along the cart path aisle, we’ll add a shuttle stop in front of your booth. In addition to your brand exposure to those who choose to catch a ride, an added benefit is that attendees walking through the aisles will see your company’s message as the carts roll past them.

**Commitment deadline: December 20, 2024**

**Device Charging Seating Areas ..... Pricing varies per branding opportunity**

Choose your location! Attach your company name and message to device charging seating areas in the convention center lobbies. Commodity Classic will list your company name in show materials as the exclusive sponsor of your chosen location. See Convention Center Opportunities #11, 23, 24, 29, 32, & 40 in this booklet for location details.

**#11: Lobby A; #24: Grand Concourse Blue Wall;**

**#32: Mile High Ballroom Foyer; #40: Upper Lobby D ..... \$5,000 – \$7,500 each**

These four locations are sold separately. Each comes with two coffee tables with power outlets for guests to charge their devices, comfortable seating, and one water cooler. Sponsorship includes the printing and installation of your graphics onto all four sides and the top of the coffee tables. You may provide (at sponsor’s expense) company collateral at the seating area, company-branded cups or wrap for the water cooler, and one pop-up banner at the seating area.

***Each of these four seating areas is also a location of the Commodity Classic Video Monitors (airtime on the monitors is sold separately).***

**#23: Grand Concourse Built-In Charging Station by 400s Rooms ..... \$9,500**

This built-in charging station is in the Grand Concourse near the 400s Rooms hallway and an escalator going down to the Mile High Ballroom foyer. The sponsor may brand the back wall and the vertical sides of the built-in benches. Sponsorship includes the built-in furniture and outlets. Additional fees apply for printing and installation of graphics.

**#29: Grand Concourse Built-In Charging Tables by 500s Rooms ..... \$7,500**

This location is in the Grand Concourse near the 500s Rooms hallway and an escalator going down to the Mile High Ballroom foyer. The location includes two built-in tables with power outlets and stools, and sponsor may brand the back wall of the area. Sponsorship includes use of the built-in furniture. Additional fees apply for printing and installation of graphics.

**Commitment deadline: December 20, 2024 • Artwork deadline: February 5, 2025**

\*2024 sponsors have the first right of refusal for some items listed.



## Education: Commodity Classic Main Stage presented by Successful Farming .....from **\$15,000**

Commodity Classic has partnered with Successful Farming to offer educational, timely, and entertaining content for our Main Stage, located on the trade show floor. Successful Farming will produce and manage these sessions. A variety of topics are available for sponsorship; pick your topic from Successful Farming's list and they will do all the work! Sponsorship includes recognition in Commodity Classic show materials, in a Successful Farming magazine ad promoting the Main Stage, recognition on Agriculture.com, 5 minutes of speaking time for your company representative on stage prior to the session, and air time on the stage screen between sessions.

**Commitment deadline: October 23, 2024** (to be recognized in print ad in Successful Farming magazine and Commodity Classic onsite materials) or **January 10, 2025** (to be recognized in Commodity Classic onsite materials).

## Education: Learning Centers, Opening Learning Center, and Early Riser Sessions ..... **\$8,000-16,000**

Learning Center Sessions (which include the Opening Learning Center and Early Risers) are neutral, content-rich educational sessions that address a wide range of current industry issues, provide unique perspectives, offer creative solutions and strategies, or challenge attendees to think differently about their businesses. These sessions are not meant to be product-specific or for the sponsoring company to sell or promote their products or services. Sessions should not be perceived by the attendees as a sales pitch or commercial. Learning Center Sessions are held in meeting rooms at the convention center. See 2025 Sponsor Education tab on our website for a full list of inclusions and benefits of this sponsorship and instructions on how to submit a proposal.

**Proposals due June 26, 2024**

## Education: Mini What's New Sessions ..... **\$2,400**

Mini What's New Sessions are a unique opportunity to showcase your company's newest, most innovative product or service to the nation's top producers. Sponsors present a 5-minute summary during a fast-paced back-to-back 90-minute session with other Mini What's New presenters. These presentations are held on the Commodity Classic Main Stage in the Trade Show on the morning of Monday, March 3. The products or services featured in the Mini What's New Sessions must be introduced to market no earlier than March 2, 2024. See 2025 Sponsor Education tab on our website for a full list of inclusions and benefits of this sponsorship and instructions on how to submit a proposal.

**Proposals due October 23, 2024**

## Education: What's New Sessions ..... **\$9,500**

What's New Sessions are 30 minutes long and are a unique platform to showcase to the Commodity Classic audience your company's newest innovation or service critical to agriculture's future. Think of this as a commercial or infomercial. What's New Sessions are held in meeting rooms at the convention center, and the products or services featured in the What's New Sessions must be introduced to market no earlier than March 2, 2024. Commodity Classic will promote your session in all show materials. See 2025 Sponsor Education tab on our website for a full list of inclusions and benefits of this sponsorship and instructions on how to submit a proposal.

**Proposals due October 23, 2024**





## First-Time Attendee Reception ..... \$15,000

Enjoy the opportunity to welcome first-time farmer attendees to Commodity Classic on Sunday, March 2 during a reception with complimentary beverages from 2:00-2:30 p.m. This casual event offers first-time attendees an opportunity to mingle with other new attendees and Commodity Classic leadership. Attendees will hear tips from our farmer-leaders on how to maximize their experience at Commodity Classic, and will be encouraged to ask questions. Sponsor will be recognized in an email invitation to first-time farmer attendees and in show materials promoting this event. Your representative may attend and make brief welcome remarks before the Commodity Classic Affiliate Council members take the mic. Sponsor may supply a pop-up banner sign at the event.

Commodity Classic hosted this event in 2023 as a reception and in 2024 as a lunch, where attendance was more than 200 guests. This is an excellent opportunity to get your company name in front of an eager group of farmer attendees before they set foot on the trade show floor!

**Commitment deadline: December 20, 2024**

## General Session\* ..... \$55,000



The General Session is consistently one of our highest attended events during Commodity Classic! Scheduled for Tuesday, March 4 at 3:30 p.m., this headline event will feature an inspiring keynote speaker, a conversation among leaders of the 5 presenting associations about industry challenges, and a high-level government official will be invited. Sponsorship of the General Session includes a speaking opportunity for your company representative to share your message with the audience. You may also provide branded promotional items to attendees of the General Session.

## General Support ..... \$5,000

Help us put on an outstanding event with a general support sponsorship and gain recognition by being included in the list of sponsors recognized in show materials. Or, propose your own unique sponsorship opportunity!

**Commitment deadline: January 10, 2025**

## Hotel Branding & Signage ..... Pricing varies per branding opportunity

Branding & signage opportunities are available in several Commodity Classic hotels, including:

- Hyatt Regency Denver
- Embassy Suites
- Hilton Denver City Center

See section later in this booklet for each hotel's branding opportunities.

*\*2024 sponsors have the first right of refusal for some items listed.*



**Hotel Room Key Cards** ..... **Pricing varies per hotel**

Make an impression by placing your logo or message on the hotel room keys distributed to attendees upon check-in. Customize the key card with your artwork to promote your brand and booth events. You may even include a QR code in your artwork for attendees to link to your web page. Sponsorship fee includes the printing of your double-sided art, production of the keys, shipping, and distribution of the key cards to Commodity Classic guests staying at the hotel.

Embassy Suites	\$6,000
Hampton Inn	\$3,000
Hilton Denver City Center*	\$14,000
Homewood Suites	\$3,000
Hyatt Regency Denver*	\$20,000
Le Meridien	\$3,000
The AC Hotel	\$3,000

**Commitment deadline: January 10, 2025 • Artwork deadline: January 14, 2025**

**Hotel Shuttles\*** ..... **\$35,000**

Be the exclusive sponsor of the complimentary Commodity Classic shuttles that will transport attendees from their hotel to the Convention Center. Shuttle service will be offered for approximately 12 Commodity Classic hotels. Your company name will be recognized as the shuttle sponsor on signage and show materials that list the shuttle schedule. This sponsorship also includes the opportunity to install your company messaging on the motorcoaches (printing & installation fees apply).

**Commitment deadline: December 20, 2024**

**Artwork deadline (if you choose to install branding on the motorcoaches): Late January**

**Luggage & Coat Check with Luggage Tags** ..... **\$9,500**

Be the exclusive sponsor of the Commodity Classic Luggage & Coat Check in the convention center Lobby A. This service will be provided complimentary to Commodity Classic attendees and exhibitors on all show days. The sponsor will have the opportunity to brand the area and be listed in show materials where we mention Luggage & Coat Check. In addition, luggage tags co-branded with the sponsor's logo and "Commodity Classic Save the Date 2026" will be attached to every item that is checked and offered to all attendees when they come to registration.

**Commitment deadline: November 15, 2024**

**Media Room & Media Reception\*** ..... **\$50,000**



More than 100 of the nation's top agriculture broadcast, online, and print reporters cover Commodity Classic. Our 2024 show had 154 media registrants. Get your name in front of this very influential group! This sponsorship includes branding opportunities in the Media Room and at the Media Reception. You may place your logo and signage in the Media Room and provide goodie bags or branded items to the media. At the Media Reception, your company representative will have the opportunity to address reception attendees, and you may provide goodie bags or branded items to attendees as well. Onsite signage provided by Commodity Classic at the Media Room and Media Reception will recognize your company as the sponsor of both areas.

\*2024 sponsors have the first right of refusal for some items listed.



**Mobile App\*** ..... **\$15,000**

The Commodity Classic mobile app features the most up-to-date show information such as the latest exhibitor listing, trade show floor plan, the show schedule, a listing of all sessions, speaker bios, venue maps, and more. 2024's mobile app had 3,810 unique downloads, 78,568 impressions of the sponsor's full-page ad on the app's splash screen, and 58,299 impressions of the app's menu page with the sponsor's banner ad. Be the exclusive sponsor of the Commodity Classic mobile app and receive the following:

- Your company's name and message on the splash screen. This is the screen that appears as the app is loading, and usually lasts between 1-3 seconds.
- One banner ad with linked URL at the bottom of the navigation menu. Users will see your sponsor banner every time they tap the menu icon to explore content in the app.
- "One-tap" listing on the navigation menu that links to a dedicated page about the mobile app sponsor.

**Commitment deadline: December 20, 2024 • Artwork deadline: January 10, 2025**

**Pancake Brunch *NEW! for 2025*** ..... **\$30,000**

Elevate the Sunday morning experience in Denver with an unforgettable Pancake Brunch, an inaugural event that combines networking, culinary delights, and engaging entertainment. Following the inspiring worship service, this is your opportunity to provide a timeless breakfast staple that has the power to unite communities. The Pancake Brunch is more than just a meal; it is a celebration of community, fellowship, and the values that bring us together.

This event presents a unique opportunity to align your brand with a shared experience that resonates with your target market. As a sponsor, you'll enjoy a range of exclusive benefits that will elevate your brand's presence and maximize your return on investment:

- Company name or logo on event materials, including signage, program guide, and digital platforms, ensuring your brand's visibility before and throughout the event.
- Opportunity to deliver a brief welcome message to attendees, allowing you to directly engage with guests and share your organization's message.
- Recognition and acknowledgment during the event, solidifying your status as a valued partner.

The sponsor is invited to provide creative activations, elements, or decor to customize the event.

**Commitment deadline: December 20, 2024**

**Program Booklet – Back Cover Ad** ..... **\$20,000**

This exclusive sponsorship is offered to just one sponsor and provides for a full-page, full-color ad across the entire back cover of the Program Booklet. The 6,000 copies of the printed onsite Program Booklet are distributed to attendees and are used as an invaluable resource for details about Commodity Classic. Securing the back cover ad location is an ideal opportunity to communicate your company message to the Commodity Classic audience, including farmers, agribusiness professionals, and media.

**Commitment deadline: December 20, 2024 • Artwork deadline: January 10, 2025**

\*2024 sponsors have the first right of refusal for some items listed.



**Program Booklet – Interior Ad ..... \$10,000**

This exclusive sponsorship is offered to just one sponsor and provides for one full-page, full-color interior ad in the Program Booklet. The 6,000 copies of the printed onsite Program Booklet are distributed to attendees and are an invaluable resource for details about Commodity Classic. This is a great opportunity to communicate your company message to the Commodity Classic audience, including farmers, agribusiness professionals, and media.

**Commitment deadline: December 20, 2024 • Artwork deadline: January 10, 2025**

**Registration Brochure\* ..... \$30,000**

This is your opportunity to reach nearly 60,000 farmers with your company name and message in a full-color ad in the registration brochure. Your third-page, full-color ad is the only exhibitor ad included in the brochure. The registration brochure is mailed in the Fall to all members of ASA, NCGA, NAWG, and NSP, as well as registrants from the past three Commodity Classics. **NEW for 2025!** The Registration Brochure sponsor will be recognized in an eblast in November 2024 sent to past registrants and those on Commodity Classic’s electronic mailing list to announce registration opening soon.

**Commitment deadline: September 15, 2024 • Artwork deadline: September 30, 2024**

**Registration Tote Bags\* ..... \$38,000**



Your company’s logo or name will be prominently displayed on tote bags distributed at registration to Commodity Classic attendees. Attendees will see your company brand while using these tote bags during Commodity Classic, and many continue using their tote bags once back at home, extending the visibility of your brand.

**Reusable Water Bottles ..... \$30,000**

Reusable water bottles with your company logo or name printed on them will be offered to all Commodity Classic attendees at the registration desk.

**Commitment deadline: November 15, 2024**

**Spin It to Win It ..... \$5,000**

This sponsorship is the chance to have Spin It to Win It, a mobile gameshow, hosted in your booth. At the published time, the prize wheel will arrive in your booth with a host and sound system. As participants gather, they get a raffle ticket making them eligible to win a chance to spin the wheel. Three tickets are drawn, and each winner gets the opportunity to spin the wheel for a cash prize ranging from \$100 to \$2,500. The game lasts approximately 15-20 minutes. Before winners are drawn, you will have the opportunity to distribute samples and get on the mic to share your company’s message with the crowd gathered for the game. Your sponsorship includes the game show in your booth, the cash prizes, and recognition of Spin It to Win It sponsorship on the Commodity Classic website and app and in onsite materials. Twelve sponsorships available.

**Commitment deadline: December 20, 2024**

\*2024 sponsors have the first right of refusal for some items listed.



### Trade Show Grand Opening & Daily Sponsor (Day 1: Sunday)\* ..... **\$27,500**



Your company will be highlighted as the exclusive sponsor of the Trade Show Grand Opening & Day 1. This sponsorship includes:

- Complimentary beverages (coffee or soft drinks) outside of the Trade Show Hall F entrance from 2:30-3:30 p.m. on Sunday, March 2. Sponsorship includes the beverages and the catering staff to distribute. This time frame covers the gathering time prior to the trade show opening through 30 minutes after the show opens. Company representatives may greet attendees at the Hall F entrance where the beverages will be offered. You may provide company-branded cups and/or napkins.
- Opportunity to address the crowd gathered for the Grand Opening Ribbon Cutting in the A/F Lobby just prior to the show opening at 3:00 p.m.
- Company representatives may greet attendees at any of the Trade Show entrances.
- Signage with your company's logo will be placed by Commodity Classic at trade show entrances on Sunday, March 2.
- Booth drawing (if company chooses to have one) is mentioned in the onsite Program Booklet (deadlines apply).
- Recognition on Commodity Classic Website, Mobile App, and Program Booklet identifying your company as the exclusive Trade Show Grand Opening & Daily Sponsor (deadlines apply).
- Company may provide a brief company blurb (approx. 40-50 words) for the Trade Show details section on the website (deadlines apply).

### Trade Show & Lunch Daily Sponsor (Day 2: Monday)\* ..... **\$55,000**



Your company will be highlighted as the exclusive sponsor of Trade Show & Lunch Day 2. The attendee lunch is historically held on the trade show floor, but this year will be held in a ballroom located above the exhibit hall.

Sponsorship includes:

- Up to 45 minutes on the Commodity Classic Main Stage, located in the trade show, to present your session (topic to be approved by Commodity Classic).
- Company representatives may welcome attendees at the entrances to trade show and lunch.
- Lunch service area promotional opportunities (provided at sponsor's cost):
  - Product message may be placed at food service location
  - Table centerpieces using company product packaging or message may be displayed
  - Cups and napkins with your company logo and booth number may be provided
- Signage with company's logo will be placed by Commodity Classic at trade show entrances and lunch ballroom entrance on Monday, March 3.
- Booth drawing (if company chooses to have one) is mentioned in the onsite Program Booklet (deadlines apply).
- Recognition on Commodity Classic Website, Mobile App, and Program Booklet identifying your company as the Trade Show & Lunch Day 2 exclusive sponsor (deadlines apply).
- Company may provide a brief company blurb (approx. 40-50 words) for the Trade Show details section on the website (deadlines apply).

\*2024 sponsors have the first right of refusal for some items listed.



## Trade Show & Lunch Daily Sponsor (Day 3: Tuesday)\* ..... \$55,000

Your company will be highlighted as the exclusive sponsor of Trade Show & Lunch Day 3. The attendee lunch is historically held on the trade show floor, but this year will be held in a ballroom located above the exhibit hall.

Sponsorship includes:

- Up to 45 minutes on the Commodity Classic Main Stage, located in the trade show, to present your session (topic to be approved by Commodity Classic).
- Company representatives may welcome attendees at the entrances to trade show and lunch.
- Lunch service area promotional opportunities (provided at sponsor's cost):
  - Product message may be placed at food service location
  - Table centerpieces using company product packaging or message may be displayed
  - Cups and napkins with your company logo and booth number may be provided
- Signage with company's logo will be placed by Commodity Classic at trade show entrances and lunch ballroom entrance on Tuesday, March 4.
- Booth drawing (if company chooses to have one) is mentioned in the onsite Program Booklet (deadlines apply).
- Recognition on Commodity Classic Website, Mobile App, and Program Booklet identifying your company as the Trade Show & Lunch Day 3 exclusive sponsor (deadlines apply).
- Company may provide a brief company blurb (approx. 40-50 words) for the Trade Show details section on the website (deadlines apply).

**Commitment deadline: December 20, 2024**

## Video Monitor Advertising ..... \$5,000 – \$20,000

The Commodity Classic Video Monitors are a dynamic digital opportunity to run your company's commercial or video with sound on large LED monitors installed in four high traffic locations in the convention center lobby. Each location will include seating and a power source to encourage attendees to sit for a bit and charge their devices while watching the screen. Your content will be played in all four locations.

Your pre-recorded video of 30 to 120 seconds will be interspersed with show messages and other sponsored content on a rotating basis throughout the show days. There is plenty of on-air screen time available to provide high visibility and frequency to several video monitor sponsors. The larger Video Monitor packages include time on the Main Stage Trade Show Stage screen between presentations. See separate Video Monitor Advertising information flyer for more details. Pricing is based on the amount of airtime purchased. Packages range from \$5,000 to \$20,000.

**Commitment deadline: January 10, 2025 • Materials due: January 31, 2025**

*\*2024 sponsors have the first right of refusal for some items listed.*



**Welcome Reception ..... \$67,000**

**syngenta**® Kick off the week with a fun social opportunity for Commodity Classic attendees! The Welcome Reception will be held on Sunday, March 2 from 6:00-7:30 p.m. in the Bluebird Ballroom in the Convention Center. This beautiful new ballroom is located above the trade show and its foyer features expansive views of the Denver skyline.

Commodity Classic will provide light food & beverage and promotion of the event. As the exclusive sponsor, you are invited to set the theme and augment the event with décor, activations, entertainment, or other experiences to promote your company and create an inviting gathering opportunity. The sponsor's representatives are welcome to greet attendees and address the crowd. The Welcome Reception is open to all full-conference registrants. This strategic partnership will not only strengthen your brand's reputation but also enable attendees to connect with old friends and nurture new connections, solidifying your position as a trusted and valued partner in their Commodity Classic experience. Don't miss this chance to be a part of a fun event that will leave a lasting impression.

**WiFi\* ..... \$20,000**

Sponsor the WiFi in the convention center meeting space, trade show, and lobbies. You may creatively incorporate your company name into the name of the Commodity Classic WiFi network and password. You may feature your company logo on the WiFi splash page. Your company name will be included in show materials, including the onsite program booklet and signage, where the WiFi information is communicated.

**Commitment deadline: December 20, 2024**

**Worship Service\* ..... \$2,500**

Commodity Classic holds a non-denominational worship service open to all participants, led by the Fellowship of Christian Farmers International. Show your support of the Commodity Classic audience with your investment in this valued event. The sponsor will be recognized in show materials where the worship service details are included. In addition, the sponsor may provide company collateral or pull-up signs in the room and will be acknowledged during the service.

This year the Worship Service will be held on the morning of Sunday, March 2. Sunday is the first show day, and this will be a nice way to start off our week together. Sunday's schedule timing is as follows: the Worship Service in the morning followed immediately by the Pancake Brunch, then the Opening Learning Center Session, several What's New Sessions, Trade Show open hours, and an evening Welcome Reception.

**Commitment deadline: December 20, 2024**

*\*2024 sponsors have the first right of refusal for some items listed.*



## ASSOCIATION-SPECIFIC EVENTS

### ASA Awards Celebration\* ..... **Contact association representative for pricing**

Sponsor this exclusive event and your company will have a valuable presence among hundreds of key soybean customers. The celebratory nature of this event lends itself well to the presentation of national awards honoring soybean growers from across the country. Contact Melanie Fitzpatrick at (314) 754-1336 or email [mfitzpatrick@soy.org](mailto:mfitzpatrick@soy.org) for details on how to become a sponsor. Sponsorship of this association event is counted towards a company's total Commodity Classic sponsorship level.

### NCGA Winners Circle Celebration\* ..... **Contact association representative for pricing**

Align yourself with those who are truly the makers of America's crop – the state and national winners of NCGA's National Corn Yield Contest. This red-carpet evening event puts the winners in the spotlight and honors membership award winners. Contact Gaylen Holloway at (636) 733-9004 or email [holloway@ncga.com](mailto:holloway@ncga.com) for details on how to become a sponsor. Sponsorship of this association event is counted towards a company's overall Commodity Classic sponsorship level.

## SIGNAGE & BRANDING OPPORTUNITIES AT CONVENTION CENTER & HOTELS

**How it works:** Please work with Commodity Classic (Abby Podkul at [apodkul@soy.org](mailto:apodkul@soy.org) or 314-517-5971 cell) to select your branding opportunity and arrange for payment of the sponsorship location fee. Then you'll be connected with the exclusive provider who will print and install your graphics. You'll pay the printer directly for printing and installation of your graphics. In most cases this is Paramount Convention Services, but there are a few exceptions.

Please note: The Commodity Classic sponsorship location fee counts towards your company's Commodity Classic sponsorship level, but printing & installation costs paid to the printer do not count towards your company's sponsorship tally.

*\*2024 sponsors have the first right of refusal for some items listed.*



# 2025 SIGNAGE & BRANDING OPPORTUNITIES



**DENVER** | MARCH 2-4, 2025  
COLORADO CONVENTION CENTER

# CONVENTION CENTER SIGNAGE & BRANDING OPPORTUNITIES



**DENVER** | MARCH 2-4, 2025  
COLORADO CONVENTION CENTER



# Convention Center Street Level



**Blue** - Floor Cling

**Green** - Column

**Yellow** - Door/Window Cling

**Purple** - Escalator Cling

**Brown** - Stair Cling

**Orange** - Banner

**Pink** - Lounge

**Magenta** - Wall Cling



## Exhibit Level

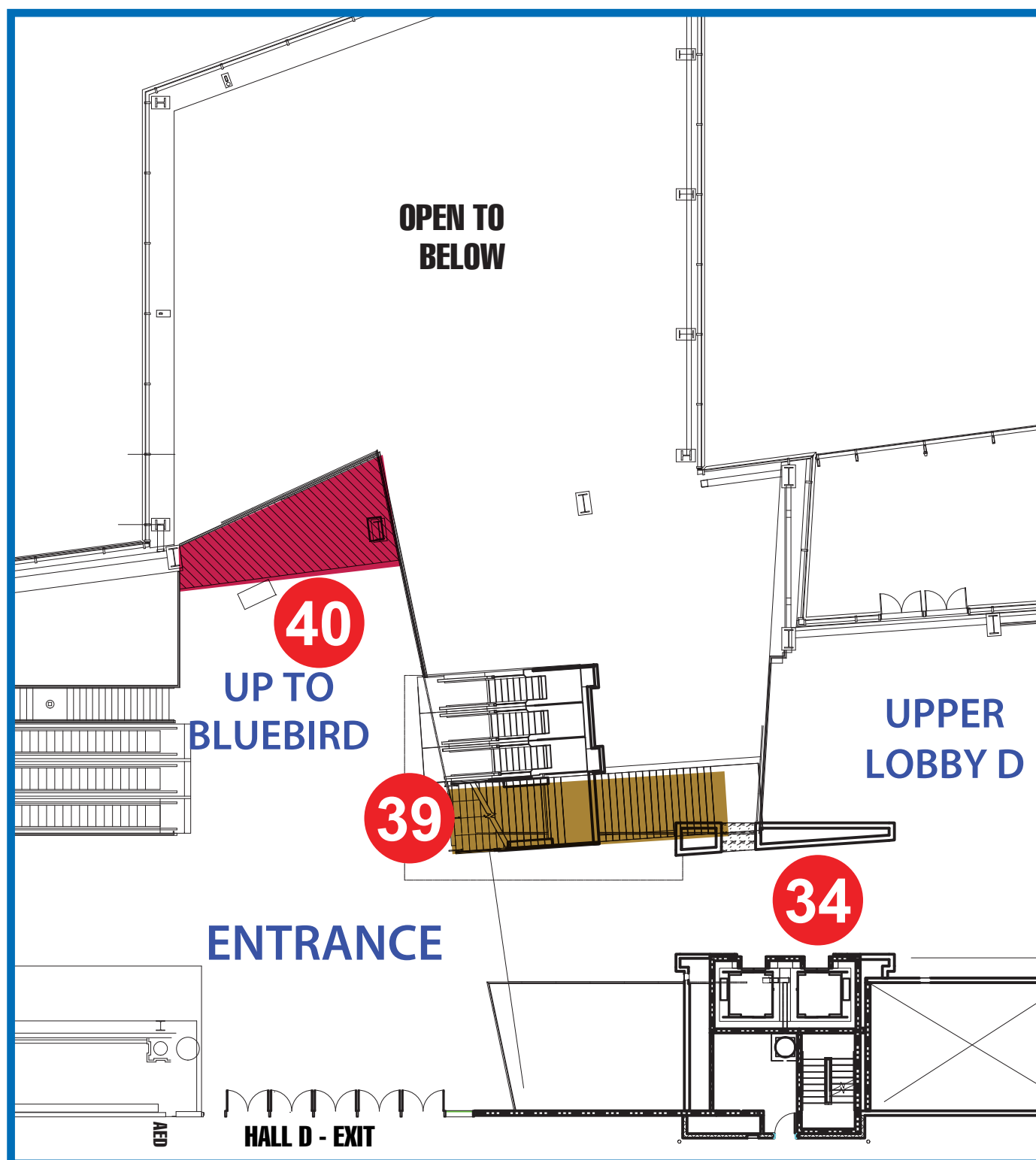

## Terrace Level

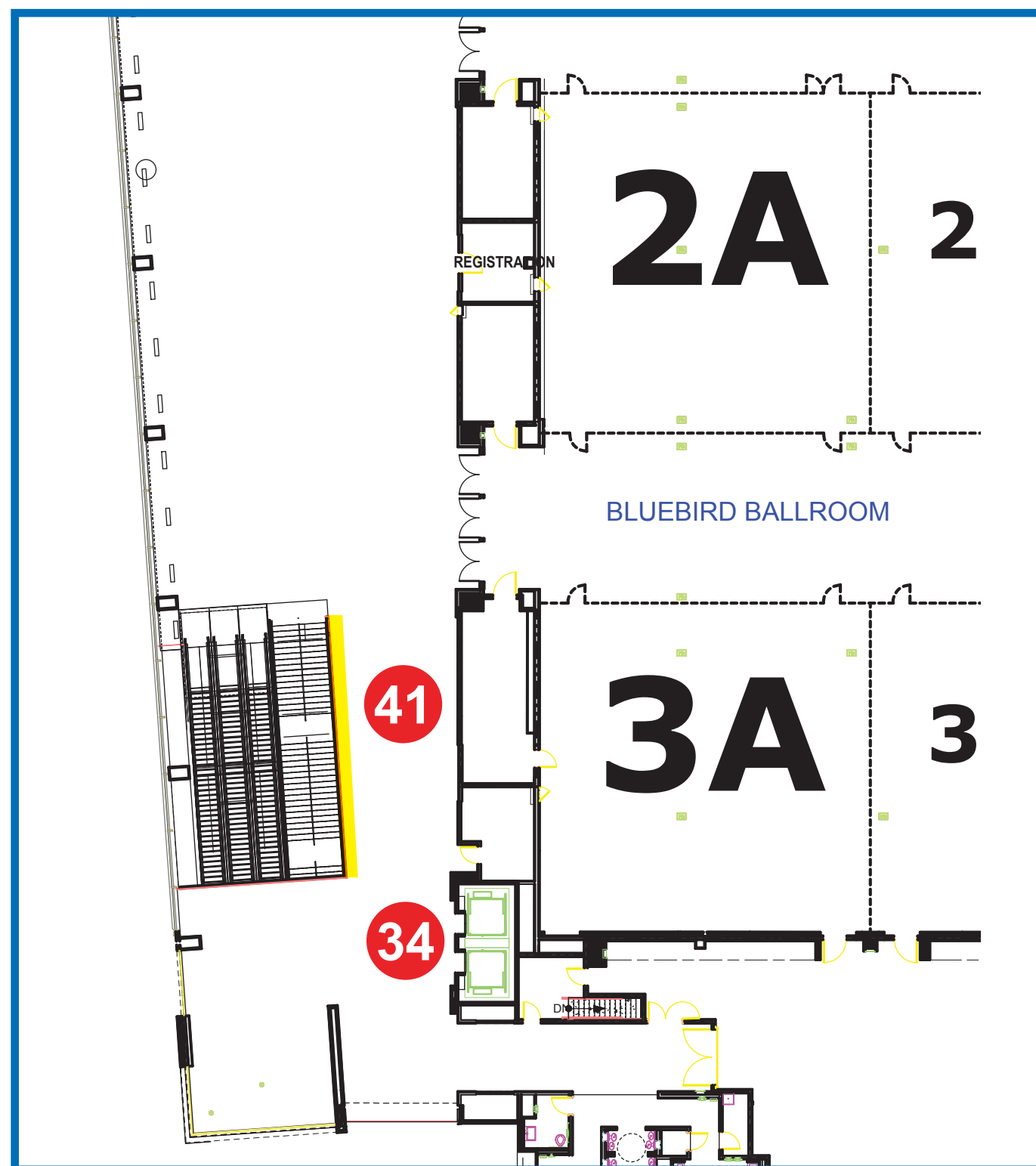

- - Floor Cling
- - Stair Cling

- - Column
- - Banner

- - Door/Window Cling
- - Lounge

- - Escalator Cling
- - Wall Cling



# Artwork Deadlines & Guidelines

The information on this sheet is for the Convention Center. Paramount Convention Services will provide the printing & installation of your Convention Center branding.

The printing & installation of your graphics for branding opportunities at hotels will be handled by the hotel's in-house provider. Please contact Abby Podkul with Commodity Classic for deadlines and guidelines for hotel branding opportunities.

## Artwork Deadline: COB Wednesday, February 5th

3% surcharge per day after February 5th

### Sending Files:

Please send all graphics as print ready PDF(200dpi+) with NO BLEEDS. Make sure all fonts are outlined and all images are linked/embedded.

If you send a file at something other than 100% please make a note of this when sending your files.

All files must be uploaded to Paramount Convention Services' FTP.

You will be provided with login and password information when you are ready to upload.

### Special Notes:

Window Clings have such a variance in size and very large quantities for some of the window banks. We are requesting that you send a mock-up along with the print ready artwork. This will ensure that your graphics are laid out correctly on site.

Column Wraps are built using Paramount's metal system. All panels will tuck into the metal structure .25" on all edges. If you have graphics that span the vertical or horizontal metal bars, please compensate for the gap of the bar (2").

**If you have any other questions or concerns regarding graphics, contact Sean Hoffert at Paramount Convention Services.**

**314.621.6677 or [SHoffert@paramountcs.com](mailto:SHoffert@paramountcs.com)**



## Atrium Window Banner

Single Sided Facing Atrium

OPPORTUNITY #1

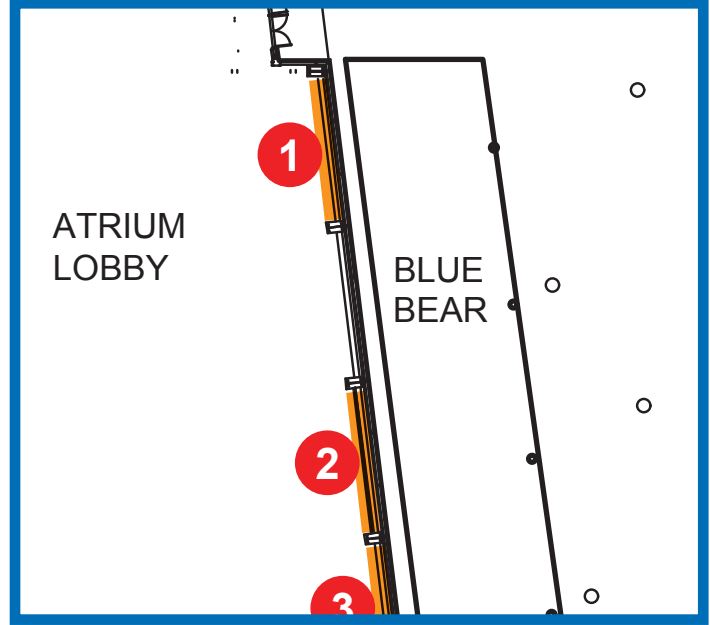

**Sponsorship Location Fee**  
\$22,000

**Printing & Installation Fee**  
\$5,035.51

### Banner

27'10" W x 13'11" H

### Additional Info

Banner installed on windows next to iconic Blue Bear statue. Banner faces in towards Atrium Lobby A/F. Great view of your banner from the entire atrium lobby and entrance to Trade Show Halls A/F.

## Atrium Window Banner

Single Sided Facing Atrium

OPPORTUNITY #2

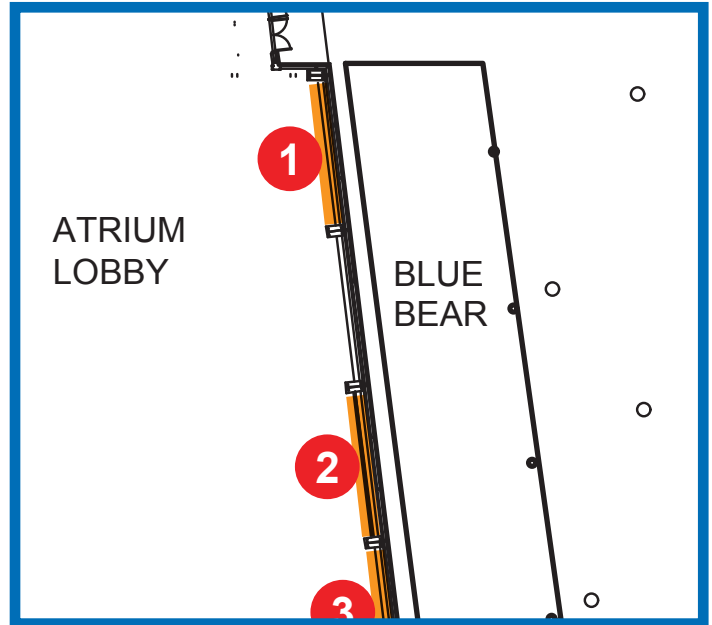
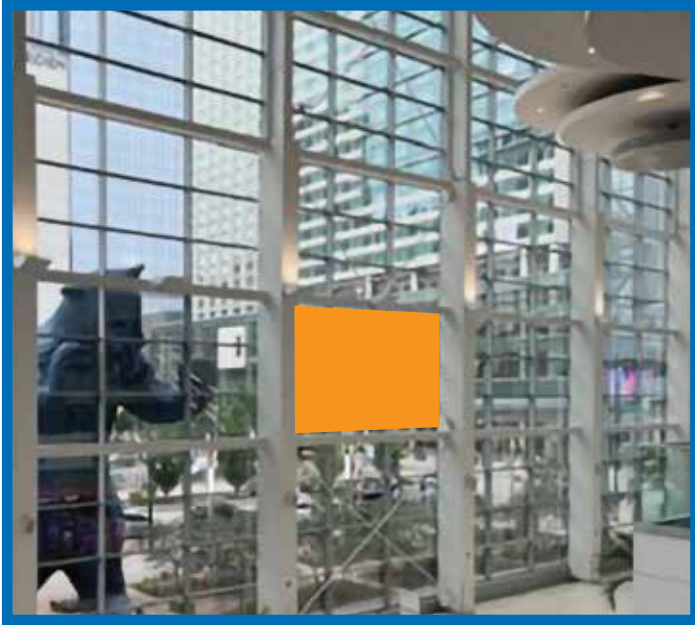

**Sponsorship Location Fee**  
\$22,000

**Printing & Installation Fee**  
\$5,035.51

### Banner

27'10" W x 13'11" H

### Additional Info

Banner installed on windows next to iconic Blue Bear statue. Banner faces in towards Atrium Lobby A/F. Great view of your banner from the entire atrium lobby and entrance to Trade Show Halls A/F.



## Atrium Window Banner

Single Sided Facing Atrium

OPPORTUNITY #3

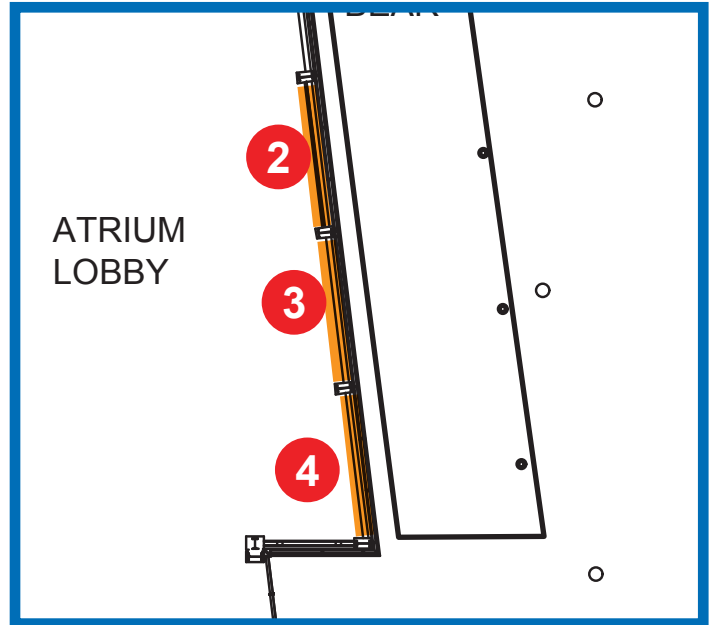

**Sponsorship Location Fee**  
\$22,000

**Printing & Installation Fee**  
\$5,035.51

### Banner

27'10" W x 13'11" H

### Additional Info

Banner installed on windows near the iconic Blue Bear statue. Banner faces in towards Atrium Lobby A/F. Great view of your banner from the entire atrium lobby and entrance to Trade Show Halls A/F.





## Atrium Window Banner

Single Sided Facing Atrium

OPPORTUNITY #4

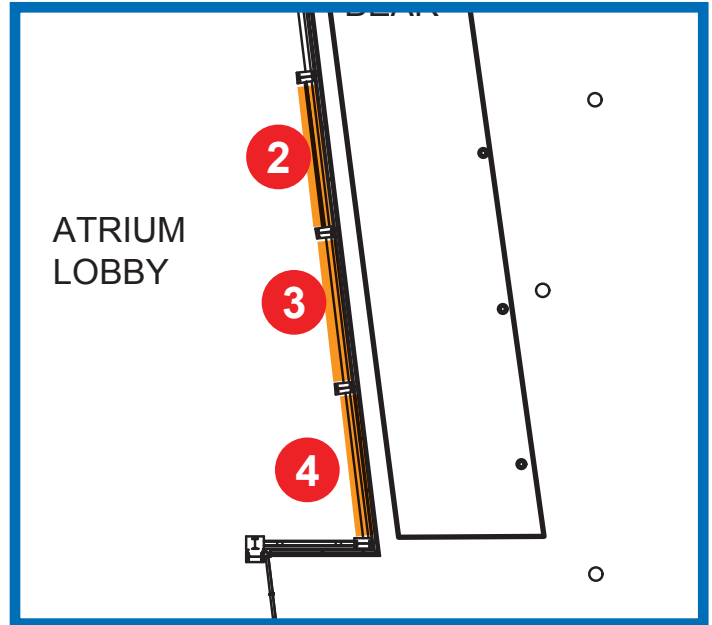

### Sponsorship Location Fee

\$22,000

### Printing & Installation Fee

\$5,035.51

### Banner

27'10" W x 13'11" H

### Additional Info

Banner installed on windows near the iconic Blue Bear statue. Banner faces in towards Atrium Lobby A/F. Great view of your banner from the entire atrium lobby and entrance to Trade Show Halls A/F.

## Atrium Lobby A/F Escalator Glass Cling

Single Sided Facing Atrium

OPPORTUNITY #5

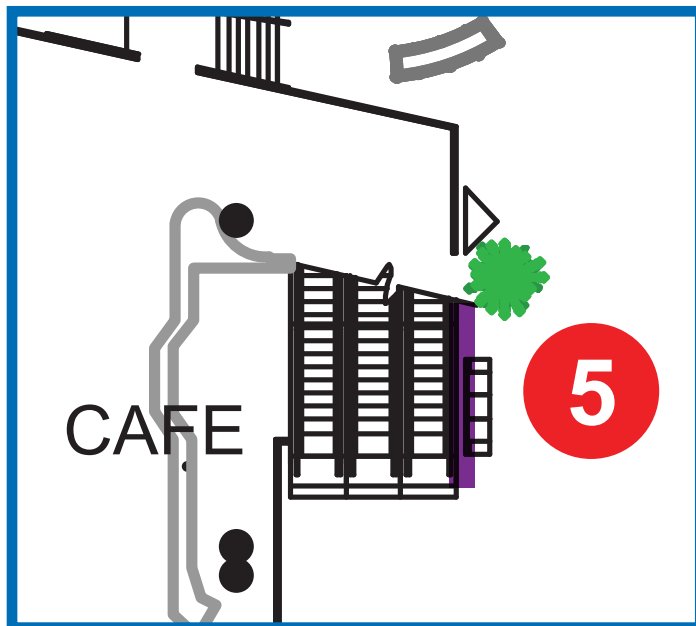

### Sponsorship Location Fee

\$7,500

### Printing & Installation Fee

\$1,139.77

### Escalator Glass

37'2" W x 23" H

### Additional Info

There is a small plastic piece in the first 5' at the bottom of the escalator for additional graphic design.

Escalator travels from the Atrium Lobby A/F up to the Trade Show Hall A/F entrance landing. Escalator is located in the center of the Atrium Lobby and will be seen by thousands of attendees who will enter the building through this lobby. Cling faces out towards the Atrium Lobby.



## Atrium Lobby A Railing Banner

Single Sided Facing Atrium

OPPORTUNITY #6

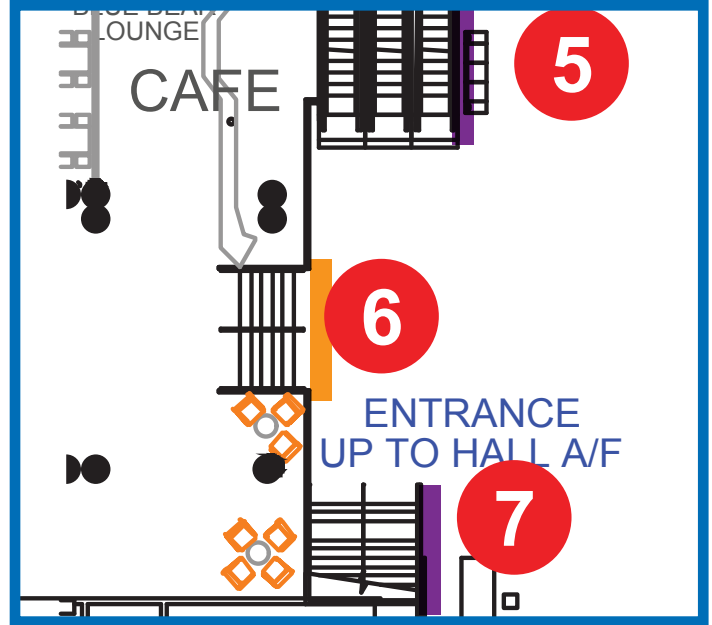

**Sponsorship Location Fee**  
\$10,000

**Printing & Installation Fee**  
\$1,170

### Banner

30' W x 3' H

### Additional Info

Banner hangs from a railing above Atrium Lobby A. Beneath it is a path towards meeting rooms and the rest of the building. Next to it are escalators and stairs that lead up to Trade Show Halls A/F entrances. Banner is single sided facing the Atrium.



## Atrium Lobby A Staircase Glass Cling

Single Sided Facing Atrium

OPPORTUNITY #7

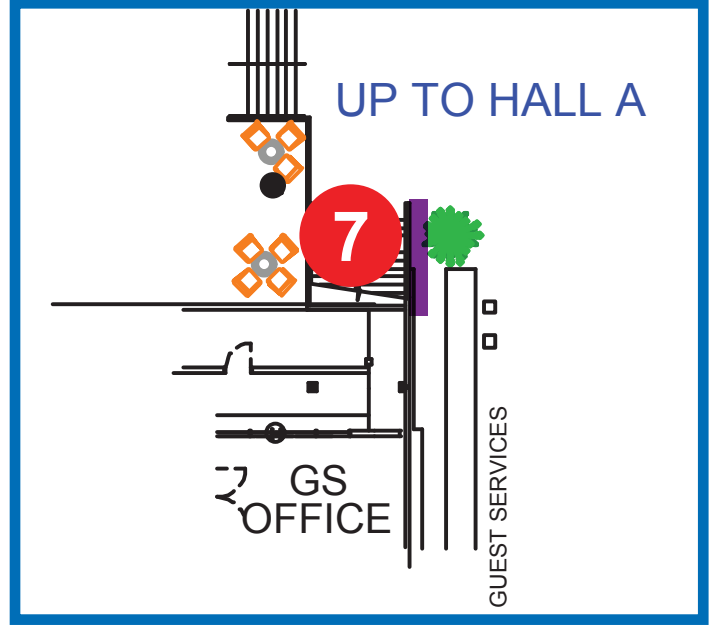

**Sponsorship Location Fee**  
\$7,500

**Printing & Installation Fee**  
\$1,533.29

### Glass Cling

- Street level to landing 21'10" W x 25" H
- Middle landing 47' W x 29.25" H
- Middle Landing to Hall A Entrance 19' 7" W x 25" H

### Additional Info

Clings start below the handrail bolts. Clings do not cover glass above the bolts.

Staircase railing cling faces out towards Atrium Lobby A.  
Stairs lead up to Trade Show Hall A.

## Atrium Lobby A Building Entry Doors

Glass Clings Above Doors Facing Atrium

OPPORTUNITY #8

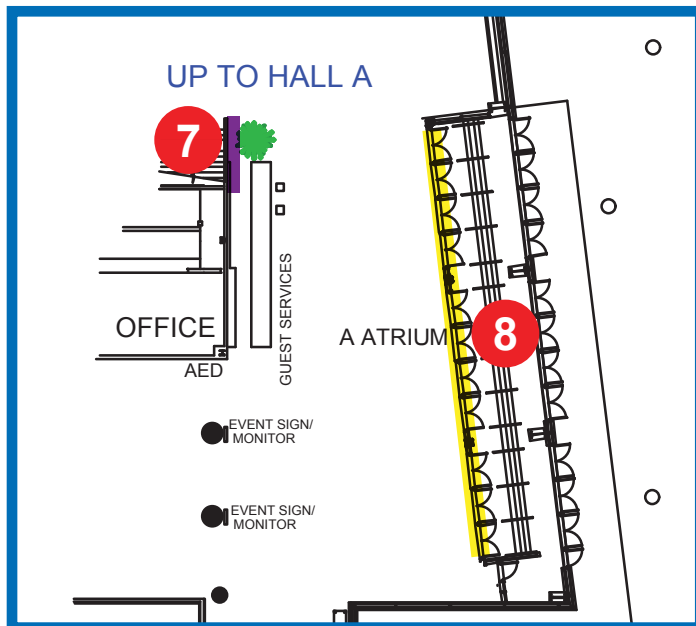

**Sponsorship Location Fee**  
**\$10,000**

**Printing & Installation Fee**  
**\$3,546.06**

### Window Cling

Left Bank	Middle Bank	Right Bank
4L 1S	1S 4L 1S	1S 3L

L- Large Window 75.25" W x 35.75" H  
S- Small Window 16.25" W x 35.75" H

### Additional Info

Glass clings face in towards the lobby. This entrance will be used by thousands of attendees.



## Atrium Lobby F Railing Banner

Single Sided Facing Atrium

OPPORTUNITY #9

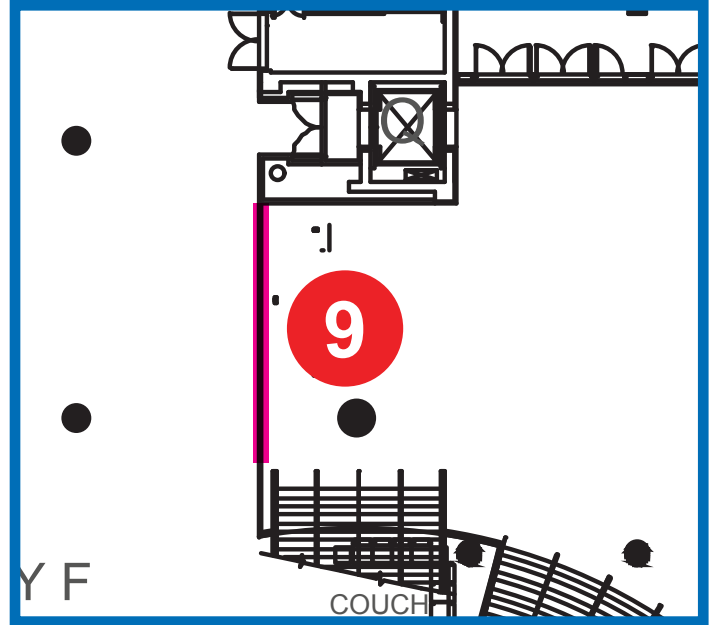

**Sponsorship Location Fee**  
\$10,000

**Printing & Installation Fee**  
\$3,822

### Banner

98' W x 3' H

### Additional Info

Banner hangs from a railing above Atrium Lobby F. Beneath it is a path towards meeting rooms and the rest of the building. Very visible when entering the building through the Atrium Lobby F doors. Banner is single sided facing the Atrium.



## Lobby A Wall Banner

Single Sided Facing Lobby A

OPPORTUNITY #10

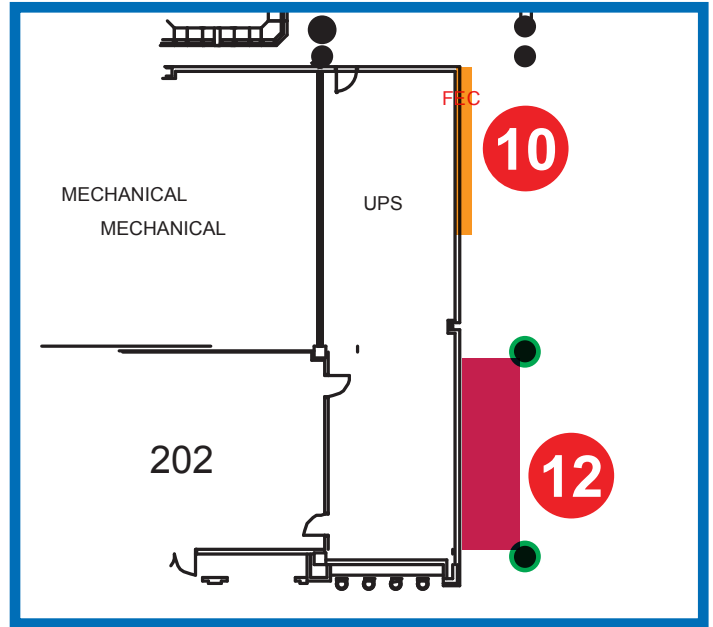

**Sponsorship Location Fee**  
\$10,000

**Printing & Installation Fee**  
\$3,640

### Banner

20' W x 14' H

### Additional Info

This single sided banner is in a prominent location in Lobby A at the start of the Grand Concourse. You'll see it as you head down the building's central corridor to reach education, meals, general session, welcome reception, closing reception, and more.

## Device Charging Seating Area - Lobby A

Commodity Classic Video Monitor Location

OPPORTUNITY #11

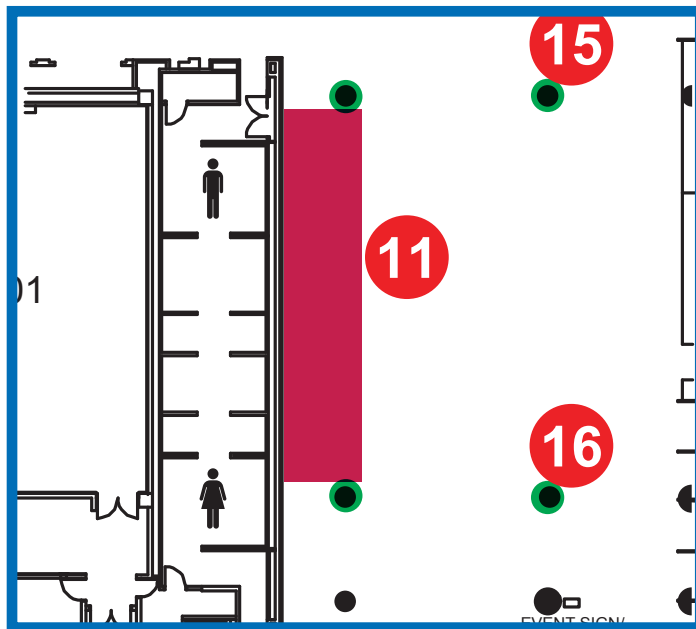

### Sponsorship Location Fee

\$7,500

### Printing & Installation Fee

\$4,237.84

### Column Wrap (x2)

14' Tall

Top (x4)

29.75" W x 70.625" H

Bottom (x4)

29.75" W x 92.125" H

### Charging Cube (x2)

Top- 48" x 48"

Side- 48" x 17" (x4)



### Additional Info

This seating area is an ideal location for Commodity Classic guests to gather, rest, and recharge their devices. Sponsorship includes seating, two branded charging coffee tables, and one water cooler. The coffee tables will be branded with your graphics on the top and all four sides, and include power outlets for attendees to charge devices. You may provide a branded water cooler wrap or branded cups for the water cooler. You may provide company collateral and one pop-up banner at the seating area.

If you wish, you may wrap the two columns that flank this space. (printing & installation fees apply for the column wrap).

\*This seating area is one of four locations with the Commodity Classic Video Monitors. These monitors will run event and sponsor messaging. (Airtime on the monitors is sold separately.)\*



## Lobby A Massage Area

Optional Column Wrap

OPPORTUNITY #12

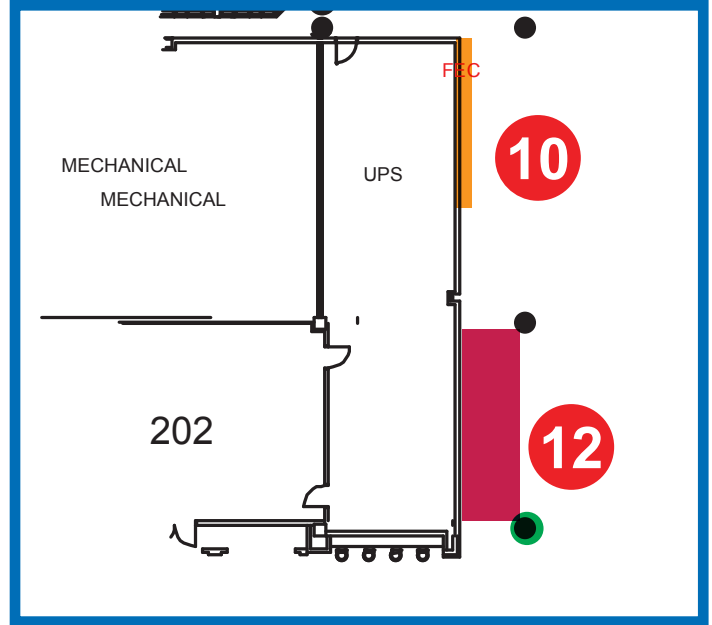

**Sponsorship Location Fee**  
\$9,500

**Printing & Installation Fee**  
\$2,118.92

### Column Wrap

14' Tall

Top (x4)  
29.75" W x 70.625" H  
Bottom (x4)  
29.75" W x 92.125" H



### Additional Info

Sponsorship of the Chair Massage Area includes the certified massage therapists and all equipment needed to provide complimentary 10-minute upper body massages for Commodity Classic attendees. Service is provided during designated hours on Sunday, Monday, and Tuesday. Sponsor may provide a pull-up banner with company messaging, and may wrap the column that flanks this space. Additional fee for printing & installation of your graphics on the column.

## Lobby A Column Wrap

One Column

OPPORTUNITY #13

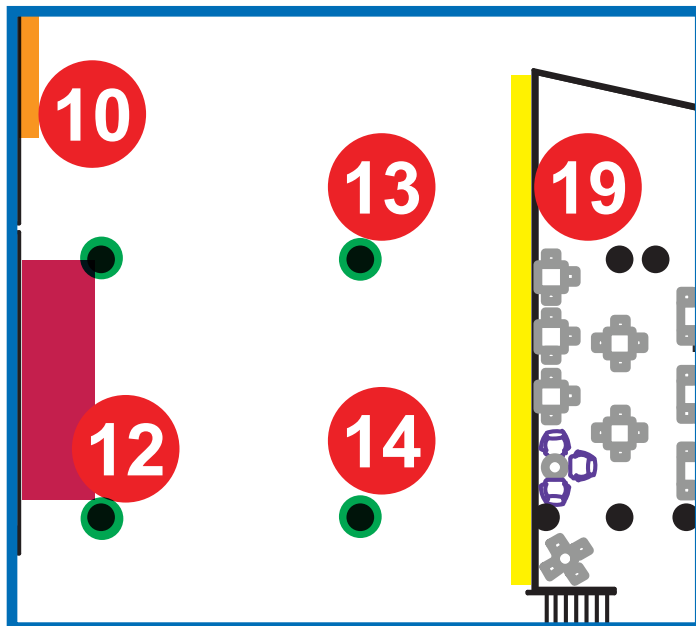

### Sponsorship Location Fee

\$3,000

### Printing & Installation Fee

\$2,118.92

### Column Wrap

14' Tall

- Top (x4)  
29.75" W x 70.625" H
- Bottom (x4)  
29.75" W x 92.125" H



### Additional Info

This part of Lobby A includes one of the Commodity Classic Video Monitor displays, Device Charging Seating Area, Chair Massage Area, Luggage & Coat Check, Tour Departures, and more.

## Lobby A Column Wrap

One Column

OPPORTUNITY #14

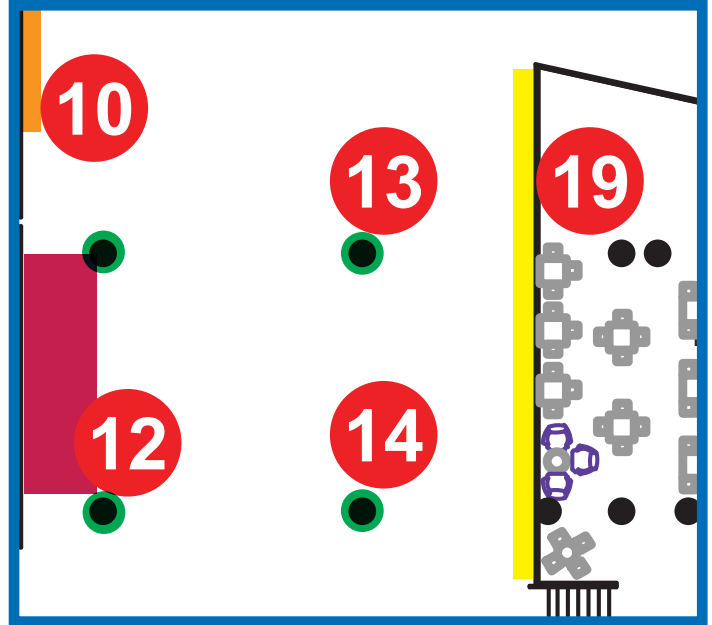

### Sponsorship Location Fee

\$3,000

### Printing & Installation Fee

\$2,118.92

### Column Wrap

14' Tall

- Top (x4)  
29.75" W x 70.625" H
- Bottom (x4)  
29.75" W x 92.125" H



### Additional Info

This part of Lobby A includes one of the Commodity Classic Video Monitor displays, Device Charging Seating Area, Chair Massage Area, Luggage & Coat Check, Tour Departures, and more.

## Lobby A Column Wrap

One Column

OPPORTUNITY #15

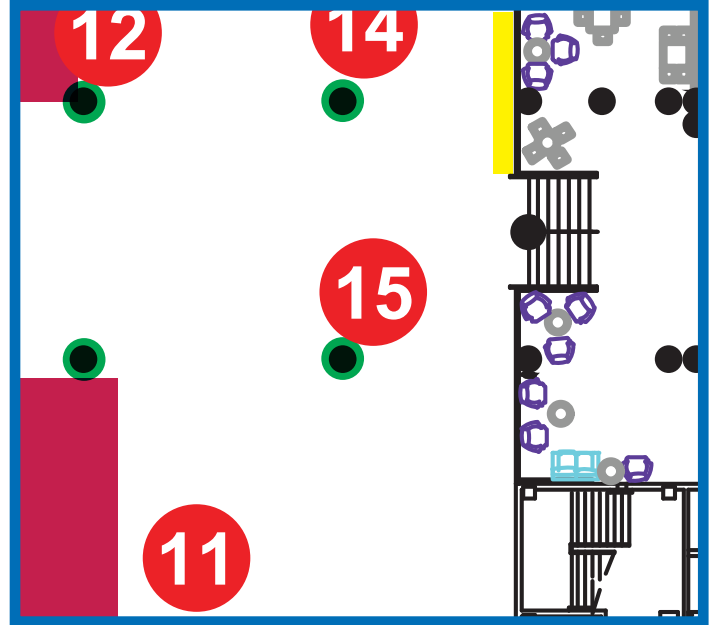

### Sponsorship Location Fee

\$3,000

### Printing & Installation Fee

\$2,118.92

### Column Wrap

14' Tall

- Top (x4)  
29.75" W x 70.625" H
- Bottom (x4)  
29.75" W x 92.125" H



### Additional Info

This part of Lobby A includes one of the Commodity Classic Video Monitor displays, Device Charging Seating Area, Chair Massage Area, Luggage & Coat Check, Tour Departures, and more.

## Lobby A Column Wrap

One Column

OPPORTUNITY #16

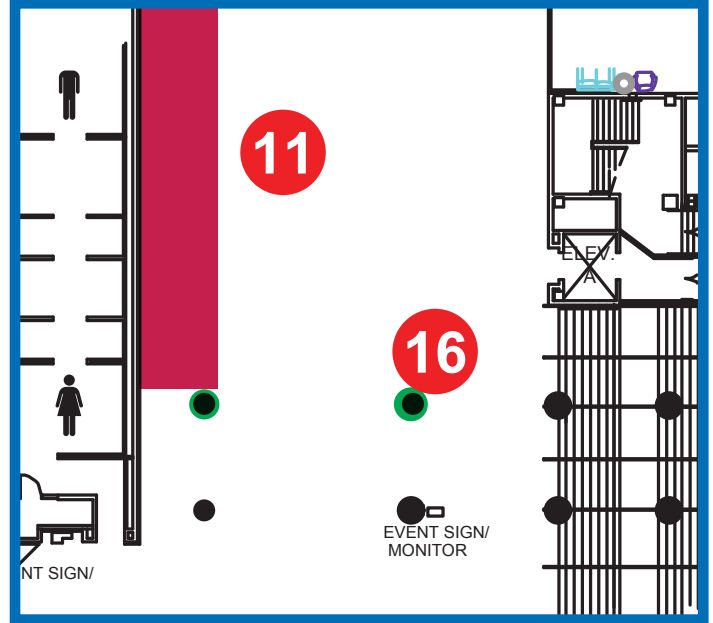

**Sponsorship Location Fee**  
\$3,000

**Printing & Installation Fee**  
\$2,118.92

### Column Wrap

14' Tall

- Top (x4)  
29.75" W x 70.625" H
- Bottom (x4)  
29.75" W x 92.125" H



### Additional Info

This part of Lobby A includes one of the Commodity Classic Video Monitor displays, Device Charging Seating Area, Chair Massage Area, Luggage & Coat Check, Tour Departures, and more.

## Lobby A Column Wrap

One Column

OPPORTUNITY #17

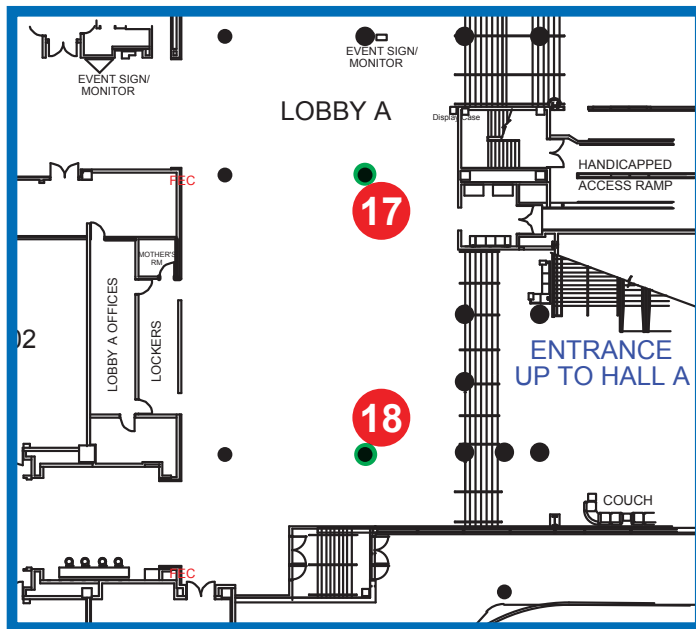

### Sponsorship Location Fee

\$3,000

### Printing & Installation Fee

\$2,118.92

### Column Wrap

14' Tall

Top (x4)

29.75" W x 70.625" H

Bottom (x4)

29.75" W x 92.125" H



### Additional Info

This part of Lobby A includes one of the Commodity Classic Video Monitor displays, Device Charging Seating Area, Chair Massage Area, Luggage & Coat Check, Tour Departures, and more.

## Lobby A Column Wrap

One Column

OPPORTUNITY #18

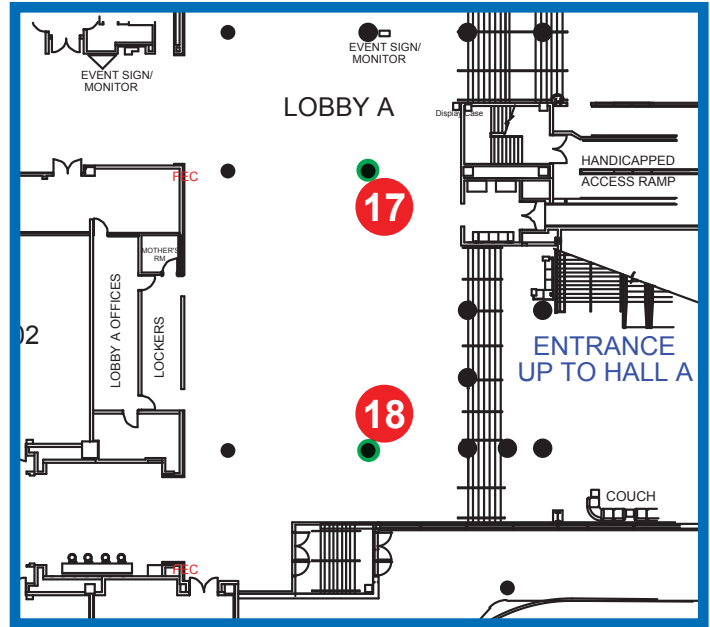

**Sponsorship Location Fee**  
\$3,000

**Printing & Installation Fee**  
\$2,118.92

### Column Wrap

14' Tall

Top (x4)  
29.75" W x 70.625" H  
Bottom (x4)  
29.75" W x 92.125" H



### Additional Info

This part of Lobby A includes one of the Commodity Classic Video Monitor displays, Device Charging Seating Area, Chair Massage Area, Luggage & Coat Check, Tour Departures, and more.

## Lobby A Café Glass Clings

Facing Lobby A

OPPORTUNITY #19

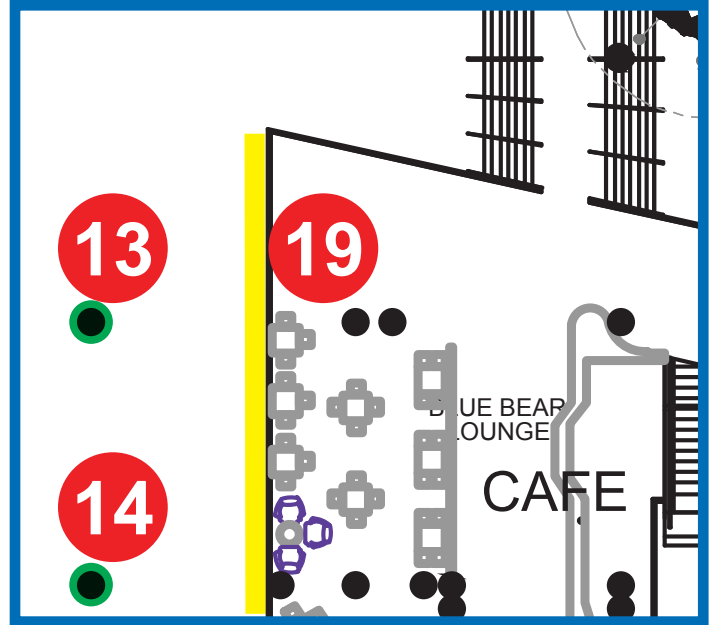

### Sponsorship Location Fee

\$4,500

### Printing & Installation Fee

\$3,145.34

### Glass Panels

- 13 Panels (left to right)
- Panels 1-10 55" W x 40.5" H
- Panels 11 61.25" W x 40.5" H
- Panels 12-13 43" W x 40.5" H

### Additional Info

Clings face into Lobby A. This part of Lobby A includes one of the Commodity Classic Video Monitor displays, Device Charging Seating Area, Chair Massage Area, Luggage & Coat Check, Tour Departures, and more.





## Grand Concourse Banner & Column Wrap

Double Sided Banner and One Column Wrap Next to Banner

OPPORTUNITY #20

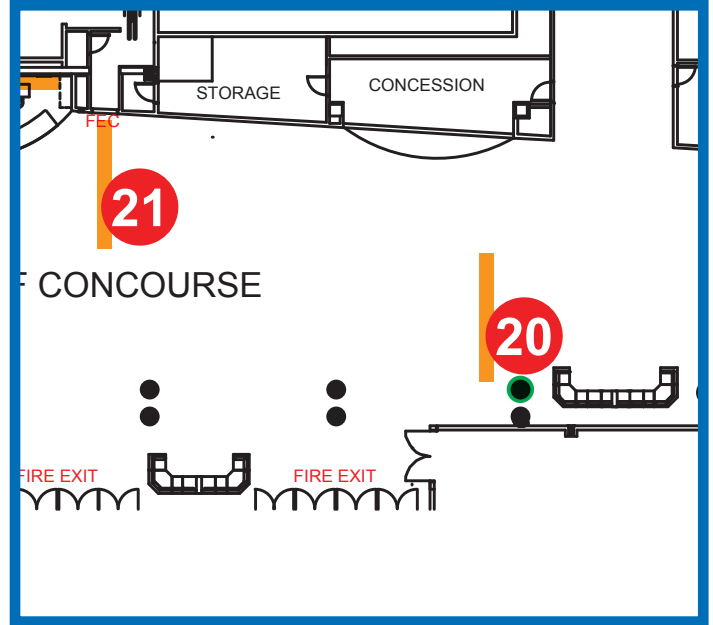

**Sponsorship Location Fee**  
\$14,000

**Printing & Installation Fee**  
\$4,458.92

### Banner

15' W x 8' H

### Column Wrap

14' Tall

Top (x4)  
29.75" W x 70.625" H  
Bottom (x4)  
29.75" W x 92.125" H

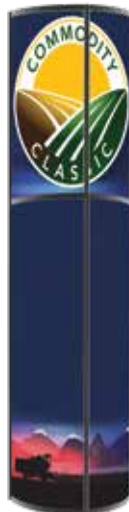

### Additional Info

Banner is double-sided. The Grand Concourse is the convention center's central corridor. It is the main path from Lobby A/F to the education rooms in Mile High Ballroom, the general session in Bellco Theater, and events held in the Bluebird Ballroom.

## Grand Concourse Banner & Column Wrap

Double Sided Banner and One Column Wrap Across From Banner

OPPORTUNITY #21

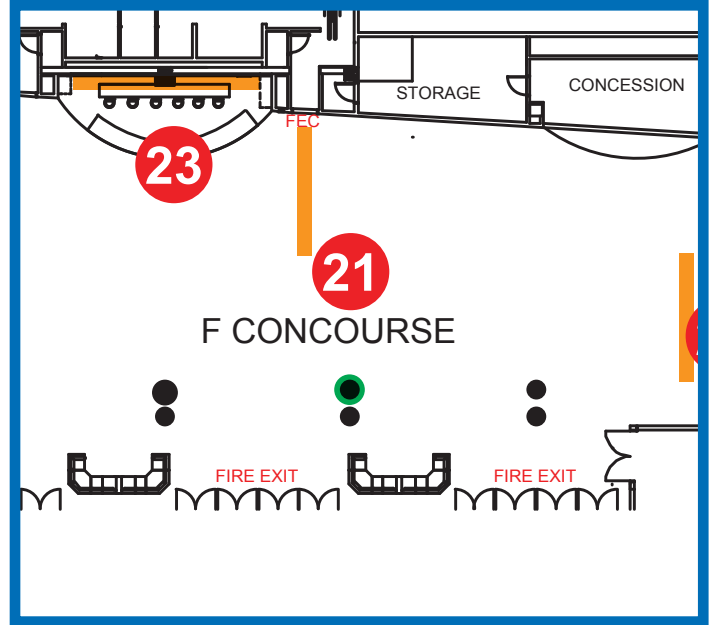

### Sponsorship Location Fee

\$14,000

### Printing & Installation Fee

\$4,458.92

### Banner

15' W x 8' H

### Column Wrap

14' Tall

Top (x4)

29.75" W x 70.625" H

Bottom (x4)

29.75" W x 92.125" H

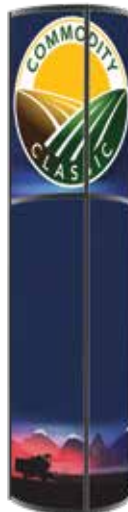

### Additional Info

Banner is double-sided. The Grand Concourse is the convention center's central corridor. It is the main path from Lobby A/F to the education rooms in Mile High Ballroom, the general session in Bellco Theater, and events held in the Bluebird Ballroom.



## Grand Concourse Banner & Column Wrap

Double Sided Banner and One Column Wrap Next to Banner

OPPORTUNITY #22

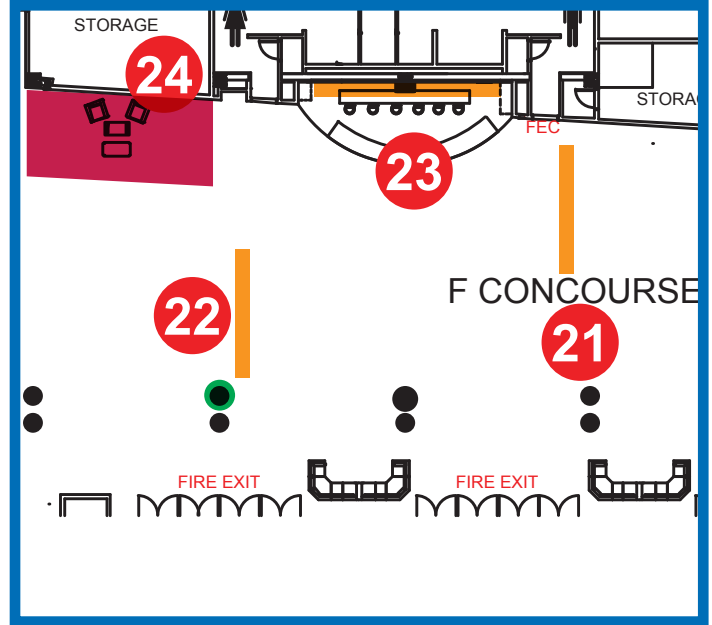

**Sponsorship Location Fee**  
\$14,000

**Printing & Installation Fee**  
\$4,458.92

### Banner

15' W x 8' H

### Column Wrap

14' Tall

Top (x4)  
29.75" W x 70.625" H  
Bottom (x4)  
29.75" W x 92.125" H

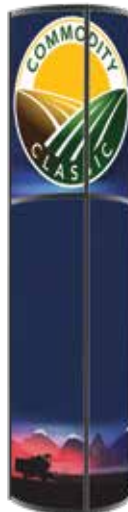

### Additional Info

Banner is double-sided. The Grand Concourse is the convention center's central corridor. It is the main path from Lobby A/F to the education rooms in Mile High Ballroom, the general session in Bellco Theater, and events held in the Bluebird Ballroom.



## Device Charging Seating Area - Grand Concourse by 400 Rooms **OPPORTUNITY #23**

Graphics on Backwalls and Clings on Curved Seating

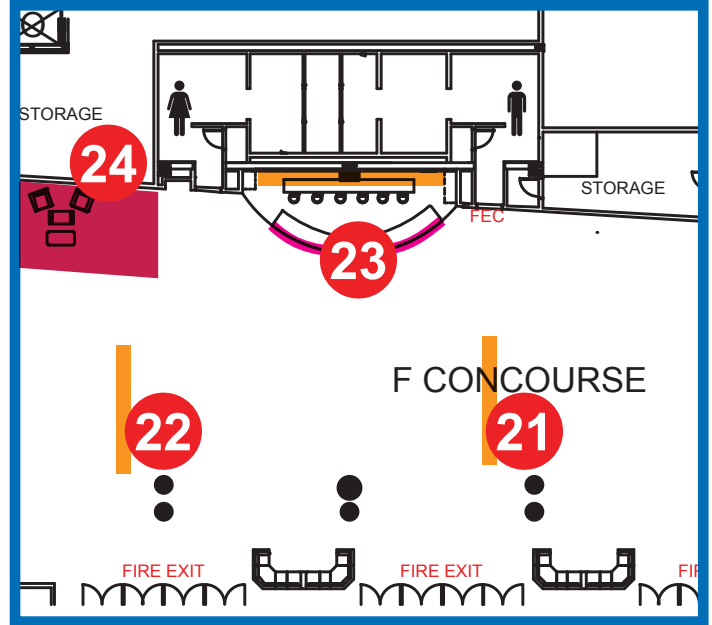

**Sponsorship Location Fee**  
**\$9,500**

### **Backwalls**

106.5" W x 88" H (103" x 55" Viewable)

### **Curved Seating**

Fronts (x2) 9'6" W x 13.5" H  
Ends (x4) 28" W x 13.5" H

**Printing & Installation Fee**  
**\$3,750**

### **Additional Info**

This area has built-in counters, stools, and benches with power outlets to charge your devices. It is located in the Grand Concourse, which is the convention center's central corridor. It is situated close to one of the escalators that go down to the Mile High Ballroom where education is held. You may brand the sides of the curved benches and the panels on the backwalls.



## Device Charging Seating Area - Grand Concourse Blue Wall **OPPORTUNITY #24**

Commodity Classic Video Monitor Location

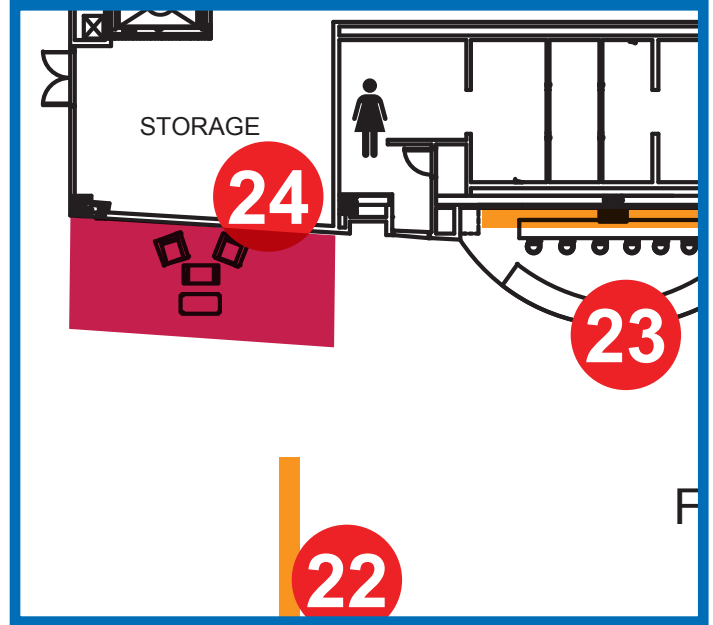

**Sponsorship Location Fee**  
\$7,500

**Printing & Installation Fee**  
\$0

### Charging Cube (x2)

Top- 48" x 48"  
Side- 48" x 17" (x4)

### Additional Info

This seating area is an ideal location for Commodity Classic guests to gather, rest, recharge their devices, and watch the Commodity Classic Video Monitors.



Sponsorship includes seating, two branded charging coffee tables, and one water cooler. The coffee tables will be branded with your graphics on the top and all four sides, and include power outlets for attendees to charge devices. You may provide a branded water cooler wrap or branded cups for the water cooler. You may provide company collateral and one pop-up banner at the seating area.

\*This seating area is one of four locations with the Commodity Classic Video Monitors. These monitors will run event and sponsor messaging. (Airtime on the monitors is sold separately.)\*



## Grand Concourse Railing Glass Clings

Facing Grand Concourse

OPPORTUNITY #25

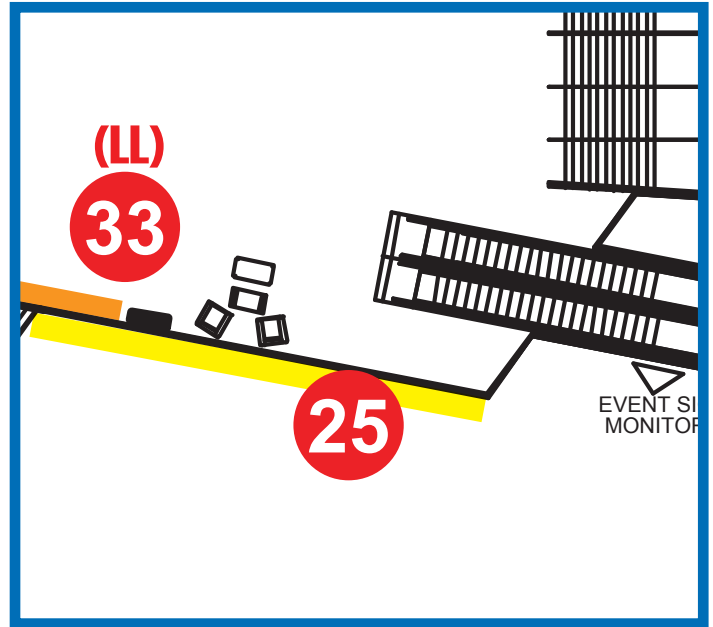

**Sponsorship Location Fee**  
\$8,500

**Printing & Installation Fee**  
\$2,363.34

### Glass Cling

- 10 Panels (L-R)
- Panels 1-3 66.5" W x 40.5" H
- Panels 4-10 59.5" W x 40.5" H

### Additional Info

Visible from the Grand Concourse, your graphics on this railing will be seen by guests as they travel through the Grand Concourse to the general session, trade show entrances, meals, and receptions. Because the glass railing is located directly above the Mile High Ballroom foyer, it will also be seen as guests approach the escalator or stairs to head down to that ballroom for educational sessions.



## Stair Landing Clings from Grand Concourse to Mile High Ballroom

Round Floor Clings on Both Landings of the Stairs

OPPORTUNITY #26

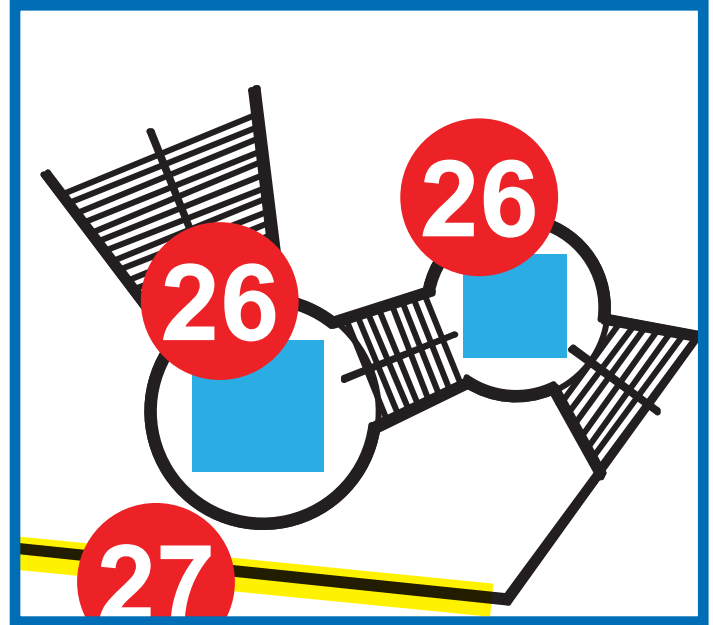
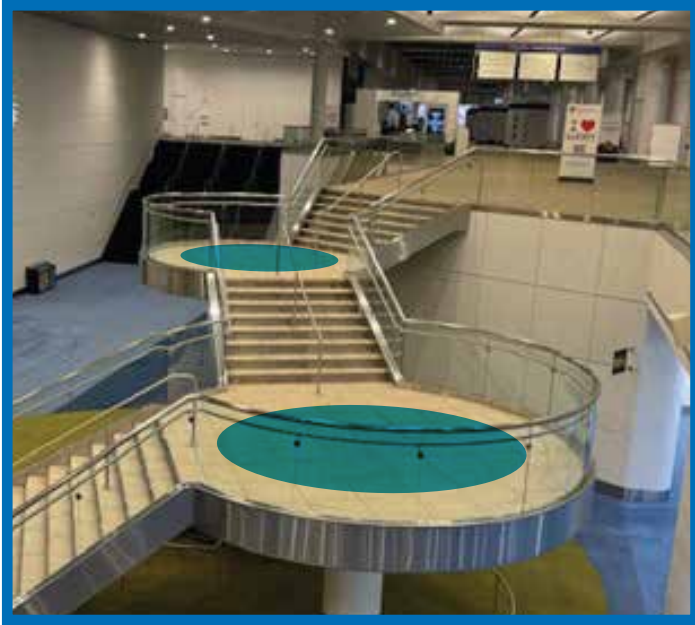

**Sponsorship Location Fee**  
\$7,500

**Printing & Installation Fee**  
\$3,600

### Floor Cling

Upper Landing 9' Diameter  
Lower Landing 12' Diameter

### Additional Info

These stairs go from the Grand Concourse to the Mile High Ballroom. Very visible from Grand Concourse even if you are not headed down the stairs.



## Grand Concourse Railing Glass Clings

Facing Grand Concourse

OPPORTUNITY #27

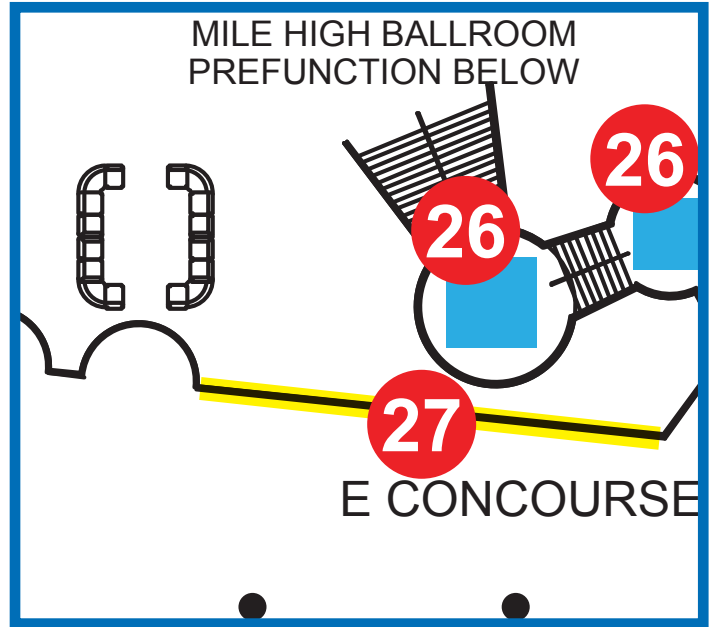

**Sponsorship Location Fee**  
\$8,500

**Printing & Installation Fee**  
\$2,906.32

### Glass Clings

- 11 Panels (L-R)
- Panel 1 63.5" W x 40.5" H
- Panel 2 53.25" W x 40.5" H
- Panels 3-11 58.5" W x 40.5" H

### Additional Info

Visible from the Grand Concourse, your graphics on this railing will be seen by guests as they travel through the Grand Concourse to the general session, trade show entrances, meals, and receptions. Because the glass railing is located directly above the Mile High Ballroom foyer, it will also be seen as guests approach the escalator or stairs to head down to that ballroom for educational sessions.



## Grand Concourse Railing Glass Clings

Facing Grand Concourse

OPPORTUNITY #28

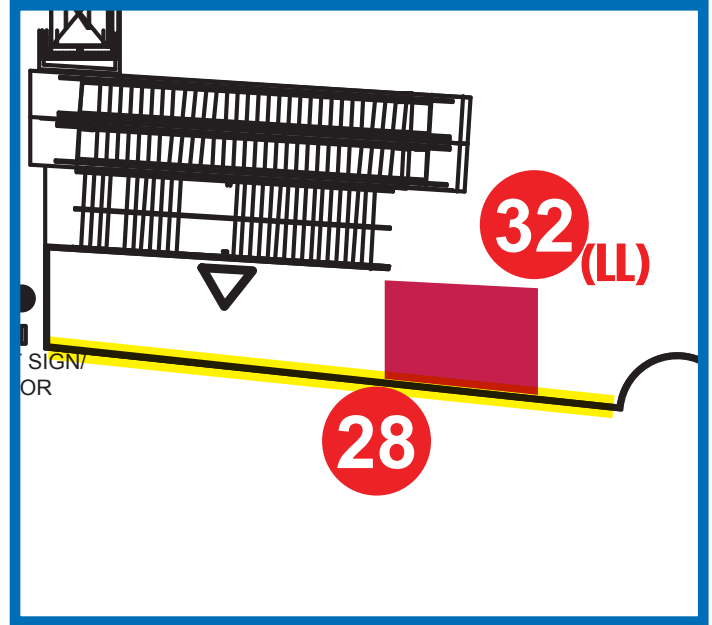
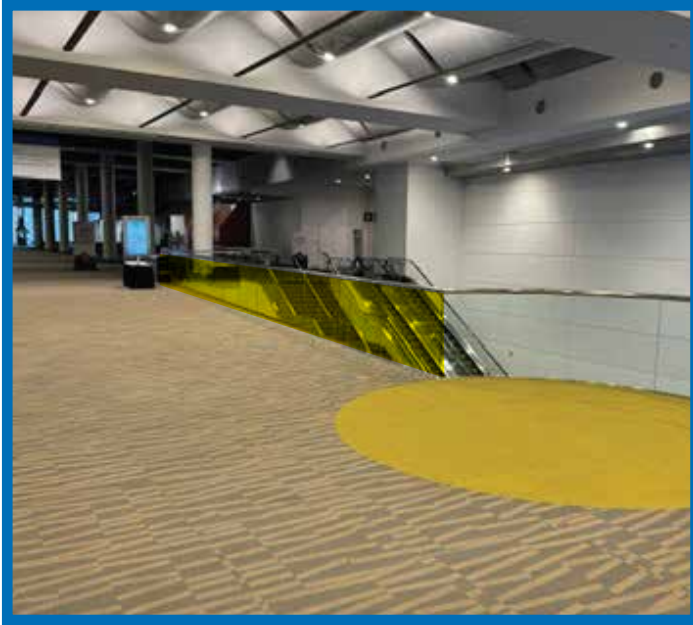

**Sponsorship Location Fee**  
\$8,500

**Printing & Installation Fee**  
\$3,561.96

### Glass Clings

- 13 Panels (L-R)
- Panels 1-11 60.75" W x 40.5" H
- Panel 12 57.25" W x 40.5" H
- Panel 13 63.5" W x 40.5" H

### Additional Info

Visible from the Grand Concourse, your graphics on this railing will be seen by guests as they travel through the Grand Concourse to the general session, trade show entrances, meals, and receptions. Because the glass railing is located directly above the Mile High Ballroom foyer, it will also be seen as guests approach the escalator or stairs to head down to that ballroom for educational sessions.

## Device Charging Seating Area - Grand Concourse by 500 Rooms Single Sided Wall Banner

OPPORTUNITY #29

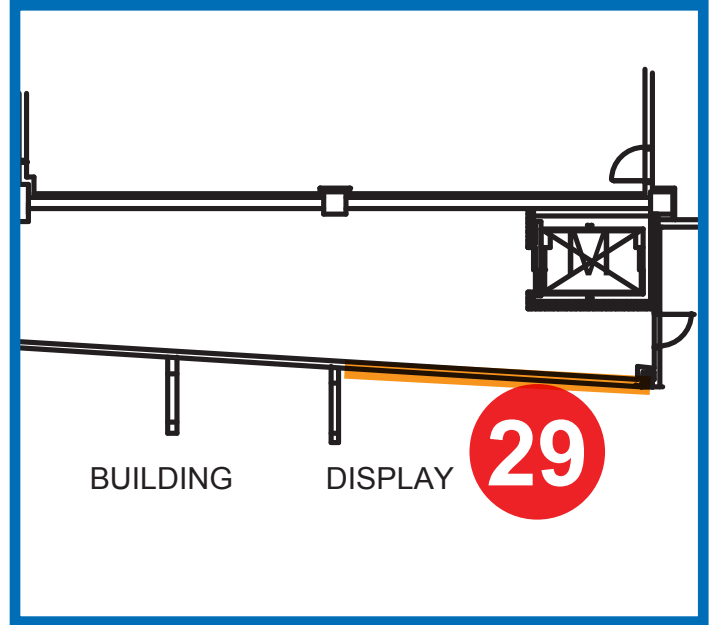

**Sponsorship Location Fee**  
\$7,500

**Printing & Installation Fee**  
\$4,901

### Banner

29' W x 13' H

### Additional Info

This area has built-in tables and stools. Power is provided at the tables. It is located in the Grand Concourse, which is the convention center's central corridor. It is situated near the top of one of the escalators that go down to the Mile High Ballroom where education is held.



## Grand Concourse Banner & Column Wrap

Double Sided Banner and One Column Wrap Next to Banner

OPPORTUNITY #30

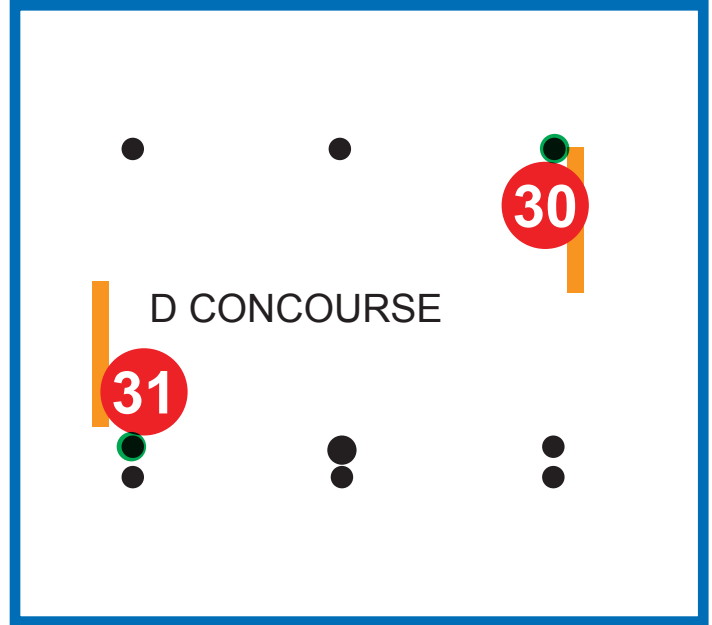

**Sponsorship Location Fee**  
\$14,000

**Printing & Installation Fee**  
\$4,458.92

### Banner

15' W x 8' H

### Column Wrap

14' Tall

Top (x4)  
29.75" W x 70.625" H  
Bottom (x4)  
29.75" W x 92.125" H

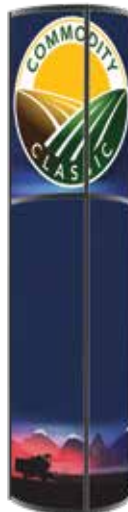

### Additional Info

Banner is double-sided. The Grand Concourse is the convention center's central corridor. It is the main path from Lobby A/F to the education rooms in Mile High Ballroom, the general session in Bellco Theater, and events held in the Bluebird Ballroom.



## Grand Concourse Banner & Column Wrap

Double Sided Banner and One Column Wrap Next to Banner

OPPORTUNITY #31

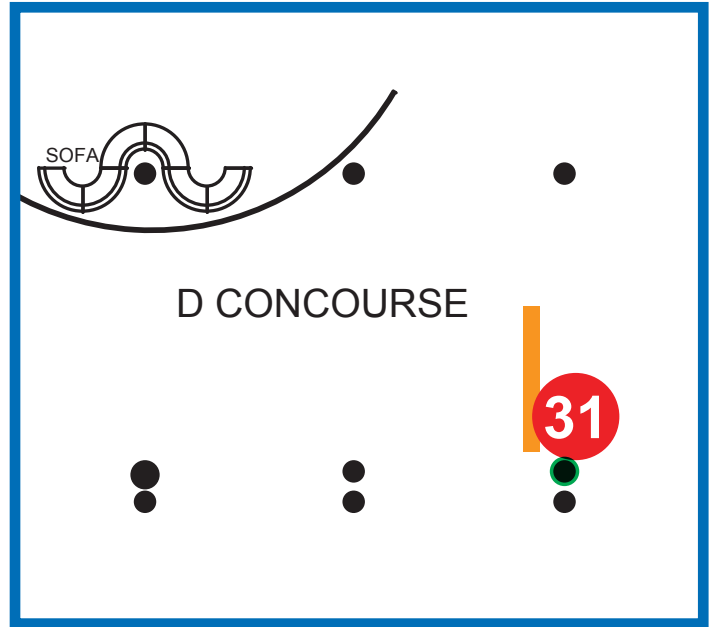

**Sponsorship Location Fee**  
\$14,000

**Printing & Installation Fee**  
\$4,458.92

### Banner

15' W x 8' H

### Column Wrap

14' Tall

Top (x4)  
29.75" W x 70.625" H  
Bottom (x4)  
29.75" W x 92.125" H

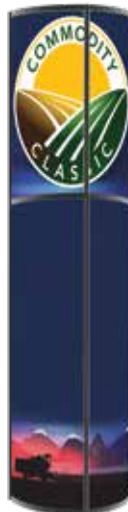

### Additional Info

Banner is double-sided. The Grand Concourse is the convention center's central corridor. It is the main path from Lobby A/F to the education rooms in Mile High Ballroom, the general session in Bellco Theater, and events held in the Bluebird Ballroom.



## Device Charging Seating Area - Mile High Ballroom Foyer

Commodity Classic Video Monitor Location

OPPORTUNITY #32

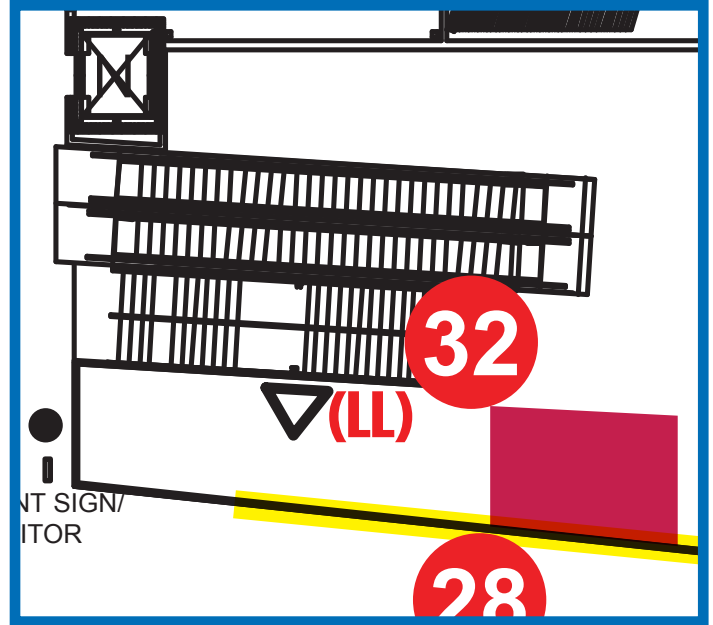

**Sponsorship Location Fee**  
\$5,000

**Printing & Installation Fee**  
\$0

### Charging Cube (x2)

Top 48" x 48"  
Sides (x4) 48" W x 17" H

### Additional Info

This seating area is an ideal location for Commodity Classic guests to gather, rest, and recharge their devices. It is located in the Mile High Ballroom foyer outside of the education meeting rooms.

Sponsorship includes seating, two branded charging coffee tables, and one water cooler. The coffee tables will be branded with your graphics on the top and all four sides, and include power outlets for attendees to charge devices. You may provide a branded water cooler wrap or branded cups for the water cooler. You may provide company collateral and one pop-up banner at the seating area.

\*This seating area is one of four locations with the Commodity Classic Video Monitors. These monitors will run event and sponsor messaging. (Airtime on the monitors is sold separately.)\*



## Mile High Ballroom Foyer Banner

Single Sided

OPPORTUNITY **#33**

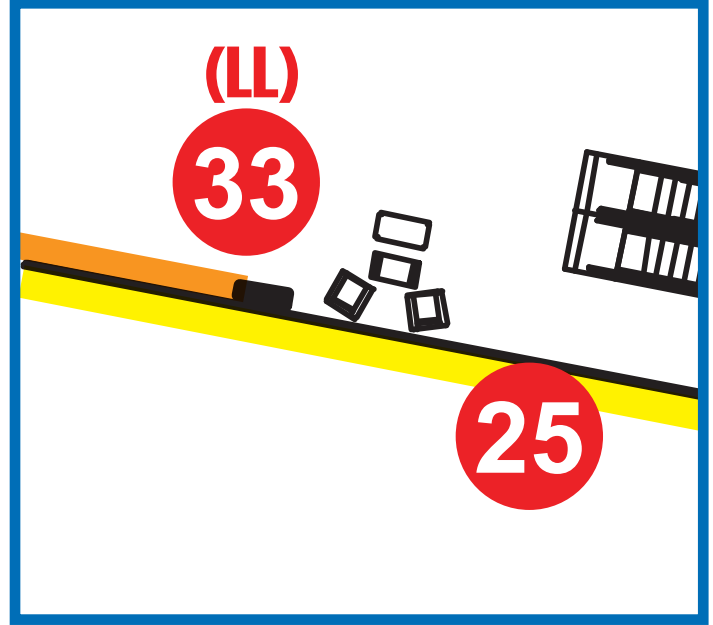

**Sponsorship Location Fee**  
\$6,500

**Printing & Installation Fee**  
\$4,056

### Banner

26' W x 12' H

### Additional Info

This large wall banner in the Mile High Ballroom foyer faces towards the meeting rooms. This ballroom will be used for educational sessions, including the Early Risers, Learning Centers, and What's New Sessions.

## Lobby D Elevator Door Clings

Inside & Outside

OPPORTUNITY **#34**

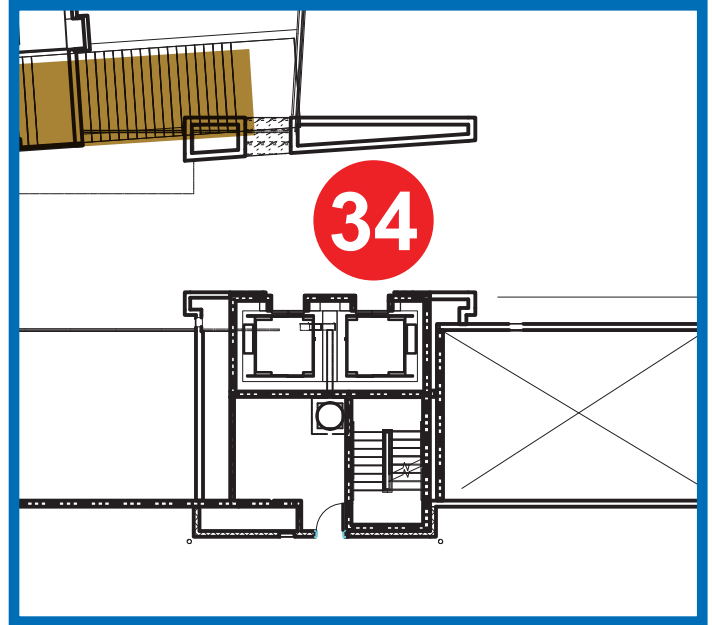

**Sponsorship Location Fee**  
\$6,500

**Printing & Installation Fee**  
\$3,966.66

### Elevator Clings

2 doors per elevator 21.25" W x 84" H

### Additional Info

Brand the inside & outside doors of this pair of elevators that stop on three levels: 1) Lobby D meeting room level, 2) trade show level next to Hall D entrance, 3) Bluebird Ballroom level.

## Lobby C/D Column Wrap

Double column

OPPORTUNITY #35

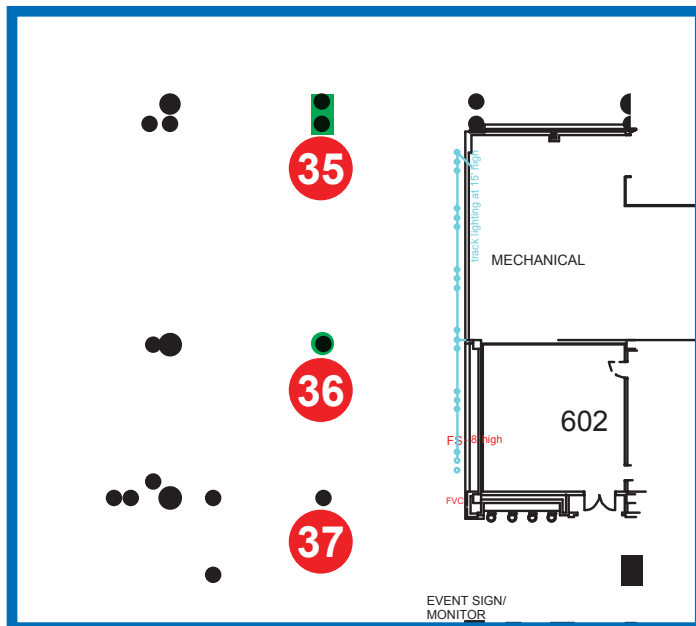

### Sponsorship Location Fee

\$3,000

### Printing & Installation Fee

\$5,913.18

### Column Wrap

Rectangle around both columns  
 Side (4 panels each side)  
 Top Row (x4) 54.5" W x 70.625" H  
 Bottom Row (x4) 54.5" W x 92.125" H

Ends (2 panels each end)  
 Top Row (x2) 54.5" W x 70.625" H  
 Bottom Row (x2) 54.5" W x 92.125" H

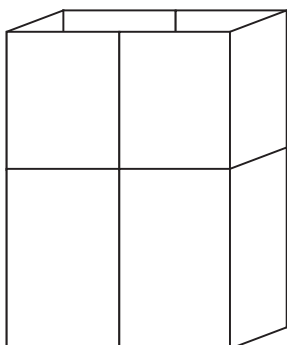

### Additional Info

This part of Lobby C/D expected to be a heavily traveled path. It is adjacent to the Bellco Theater lobby (location of General Session), and is at the base of the escalators that lead up to the Trade Show Hall D entrance and the Bluebird Ballroom (location of meals, welcome reception, closing reception, and more).





## Lobby C/D Column Wrap

OPPORTUNITY #36

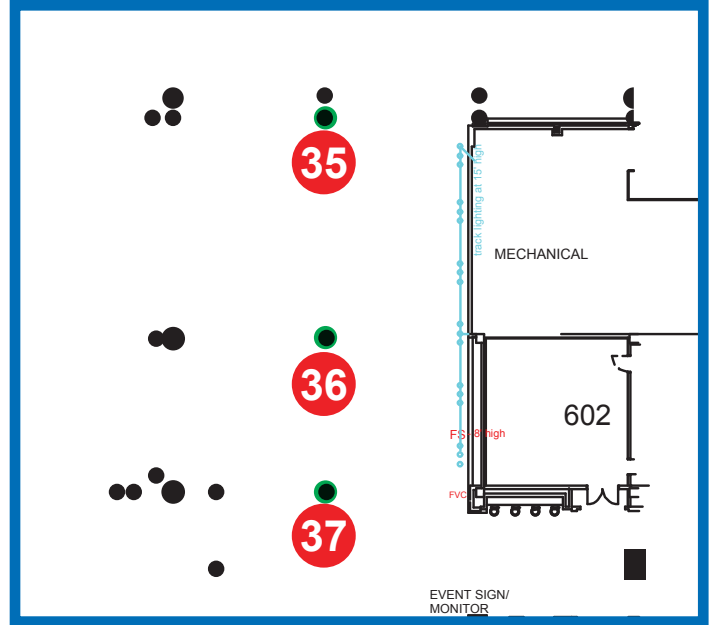

**Sponsorship Location Fee**  
\$3,000

**Printing & Installation Fee**  
\$3,037.96

### Column Wrap

14' Tall

- Top (x4)  
42.75" W x 70.625" H
- Bottom (x4)  
42.75" W x 92.125" H



### Additional Info

This part of Lobby C/D expected to be a heavily traveled path. It is adjacent to the Belco Theater lobby (location of General Session), and is at the base of the escalators that lead up to the Trade Show Hall D entrance and the Bluebird Ballroom (location of meals, welcome reception, closing reception, and more).



## Lobby C/D Column Wrap

OPPORTUNITY #37

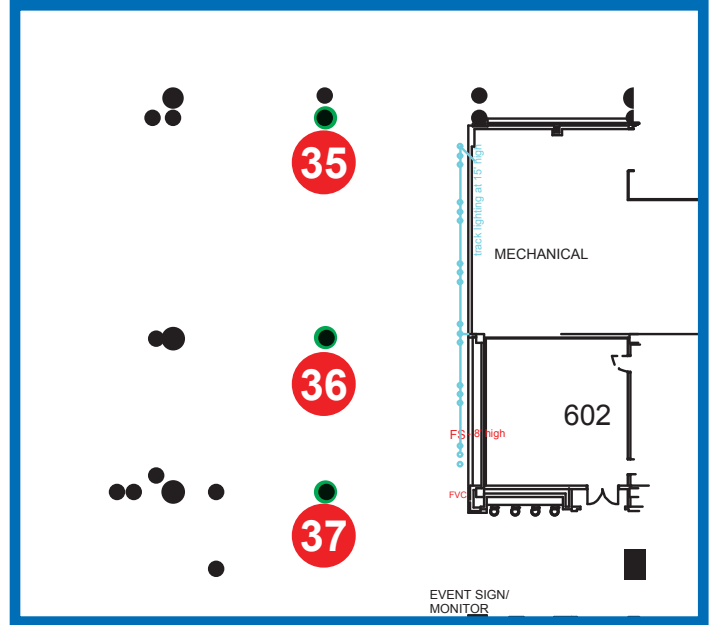

**Sponsorship Location Fee**  
\$3,000

**Printing & Installation Fee**  
\$2,118.92

### Column Wrap

14' Tall

- Top (x4)  
29.75" W x 70.625" H
- Bottom (x4)  
29.75" W x 92.125" H



### Additional Info

This part of Lobby C/D expected to be a heavily traveled path. It is adjacent to the Belco Theater lobby (location of General Session), and is at the base of the escalators that lead up to the Trade Show Hall D entrance and the Bluebird Ballroom (location of meals, welcome reception, closing reception, and more).

## Lobby C/D Column Wrap

OPPORTUNITY #38

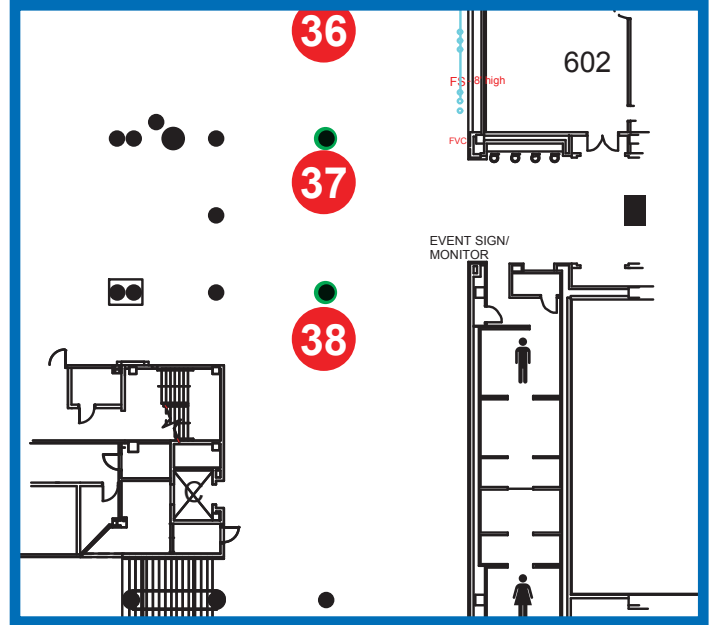

**Sponsorship Location Fee**  
\$3,000

**Printing & Installation Fee**  
\$2,118.92

### Column Wrap

14' Tall

- Top (x4)  
29.75" W x 70.625" H
- Bottom (x4)  
29.75" W x 92.125" H



### Additional Info

This part of Lobby C/D expected to be a heavily traveled path. It is adjacent to the Bellco Theater lobby (location of General Session), and is at the base of the escalators that lead up to the Trade Show Hall D entrance and the Bluebird Ballroom (location of meals, welcome reception, closing reception, and more).



## Bluebird Stair Clings

Grand Staircase to Bluebird Ballroom

OPPORTUNITY #39

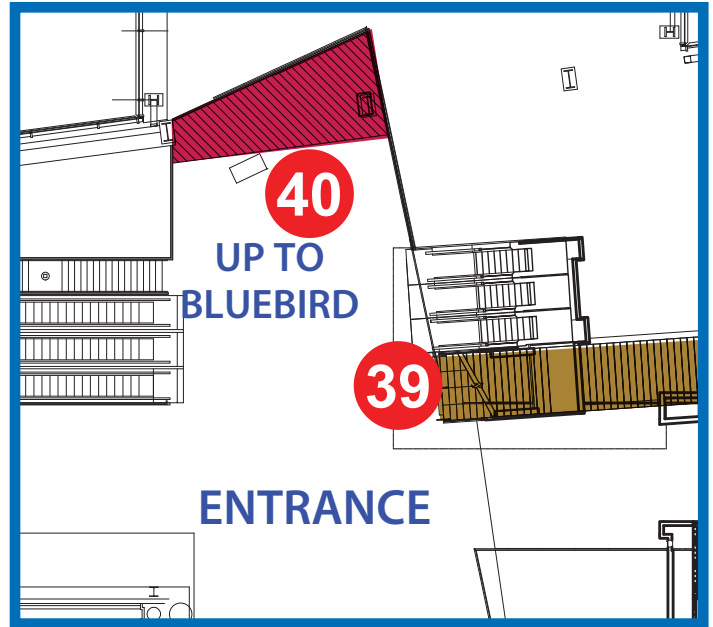
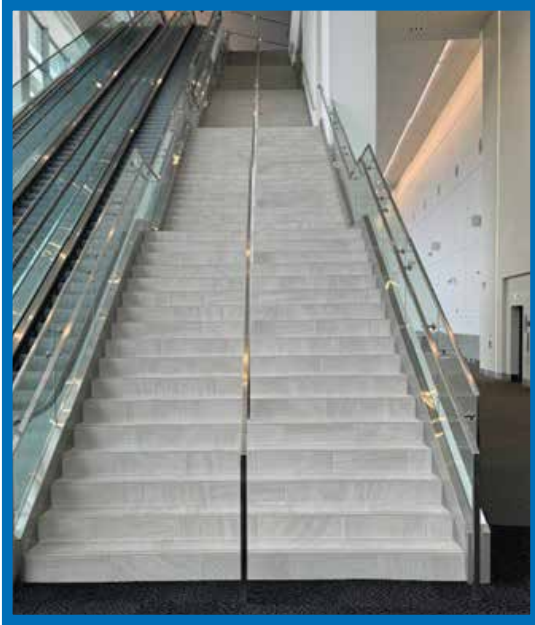

**Sponsorship Location Fee**  
\$25,000

**Printing & Installation Fee**  
\$7,372.44

### Stair Clings

- All stair risers 6.5" H
- Hall D to Bluebird
- Bank 1 (x17) 115.75" W
- Bank 2 (x18) 115.75" W
- Bank 3 (x18) 116.5" W
- Bank 4 (x18) 116.25" W
- Bank 5 (x17) 115.75" W

### Additional Info

This beautiful, LONG, staircase is located outside of Trade Show Hall D entrance. With 5 banks of steps with landings in between, it goes on and on and on. The staircase and the escalator next to it will take guests up to the Bluebird Ballroom for meals, welcome reception, closing reception, and other events.

Your message will be seen by guests who choose to take the stairs AND those who choose to ride the adjacent escalator. The escalator ride is 60-seconds, which offers great captive exposure to your message. The staircase graphics will also make a statement to anyone hanging around on the Lobby D landing outside of the trade show.

## Device Charging Seating Area - Upper Lobby D

Commodity Classic Video Monitor Location

OPPORTUNITY #40

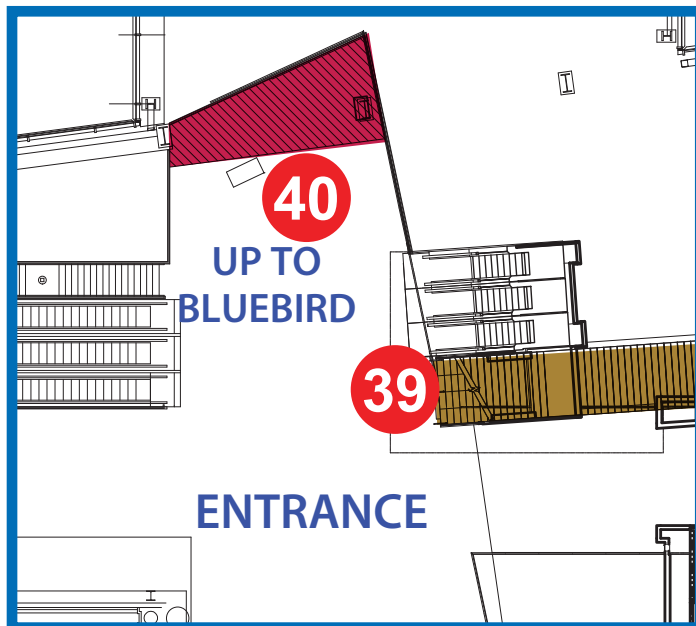
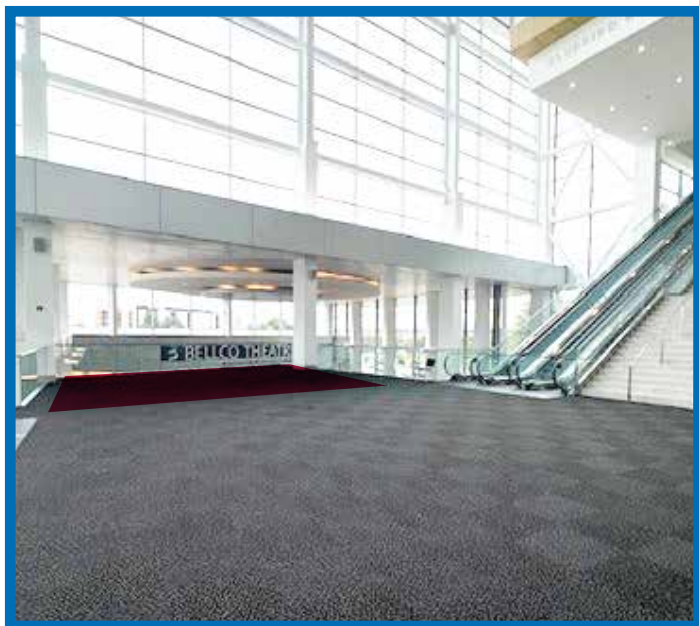

### Sponsorship Location Fee

\$7,500

### Printing & Installation Fee

\$0

### Charging Cube (x2)

Top 48" x 48"

Sides (x4) 48" W x 17" H

### Additional Info

This seating area is an ideal location for Commodity Classic guests to gather, rest, and recharge their devices. It is outside of Trade Show Hall D entrance and at the beginning of the escalators that lead up to Bluebird Ballroom.

Sponsorship includes seating, two branded charging coffee tables, and one water cooler. The coffee tables will be branded with your graphics on the top and all four sides, and include power outlets for attendees to charge devices. You may provide a branded water cooler wrap or branded cups for the water cooler. You may provide company collateral and one pop-up banner at the seating area.

\*This seating area is one of four locations with the Commodity Classic Video Monitors. These monitors will run event and sponsor messaging. (Airtime on the monitors is sold separately.)\*





## Glass Railing Clings

Above Bluebird Ballroom Stairs

OPPORTUNITY #41

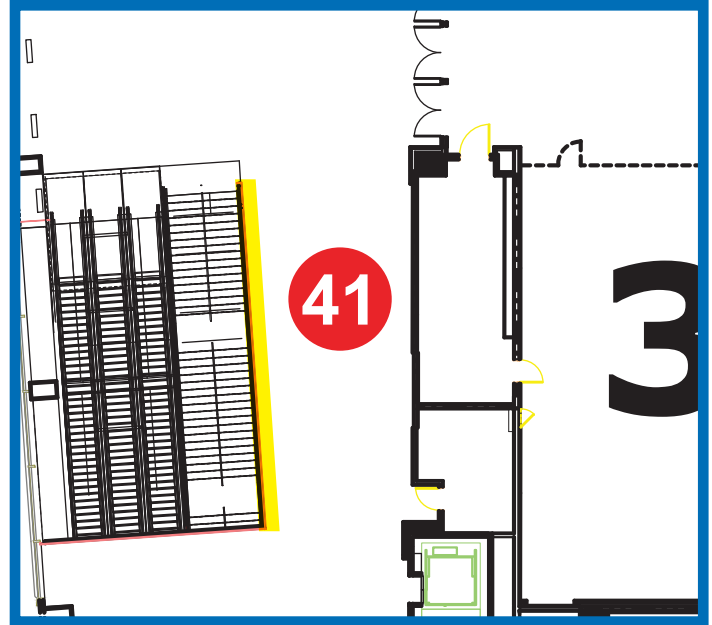

**Sponsorship Location Fee**  
\$6,500

**Printing & Installation Fee**  
\$1,755

### Glass Clings

54" W x 32.5" H (x9)

### Additional Info

This glass railing is in the Bluebird Ballroom foyer. It is located near the elevator, escalator, and staircase that attendees will take up to the Bluebird. This ballroom will be used for meals, welcome reception, closing reception, and more. Clings face in towards the foyer.



## Lobby B Registration Door Clings

Building Entrance Doors; Lower Glass Facing In

OPPORTUNITY #42

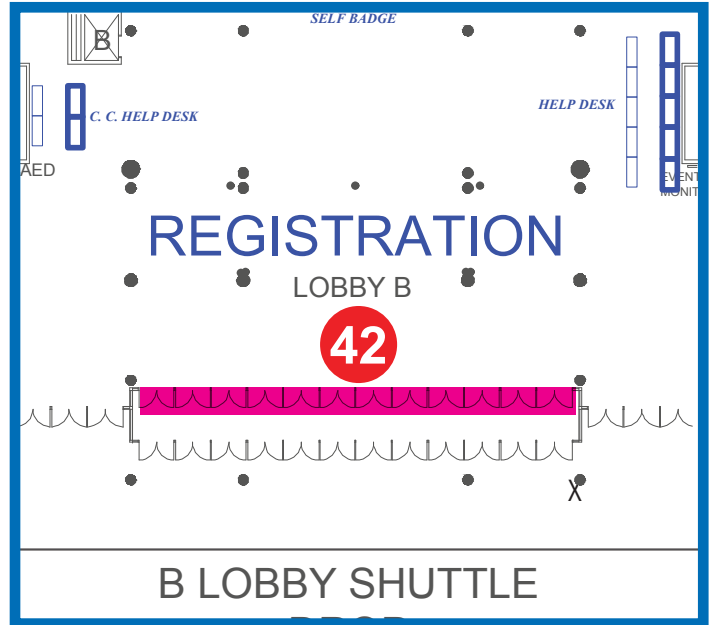

**Sponsorship Location Fee**  
\$10,000

**Printing & Installation Fee**  
\$2,463.99

### Door Clings

33" W x 28.25" H (x24)

### Additional Info

Lobby B is the location of Commodity Classic registration, housing help desk, general info service desk, and association service desks. Lobby B is also the building entrance that thousands of attendees arriving by hotel shuttle will enter.

## Lobby B Registration Wall Cling

Single Sided in Registration Area

OPPORTUNITY #43

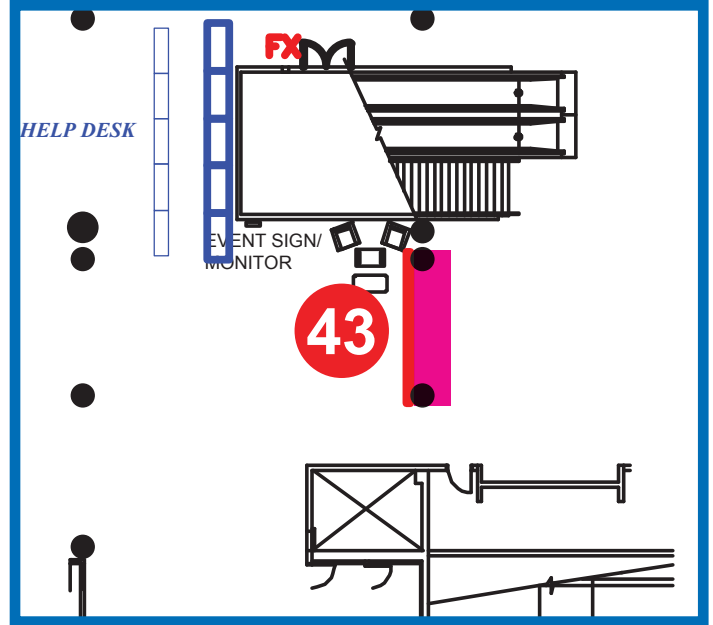

**Sponsorship Location Fee**  
\$4,500

**Printing & Installation Fee**  
\$2,798.16

### Wall Cling

25'9" W x 81.5" H

### Additional Info

Lobby B is the location of Commodity Classic registration, housing help desk, general info service desk, and association service desks. Lobby B is also the building entrance that thousands of attendees arriving by hotel shuttle will enter.





## Lobby B Registration Wall Cling

Single Sided in Registration Area

OPPORTUNITY #44

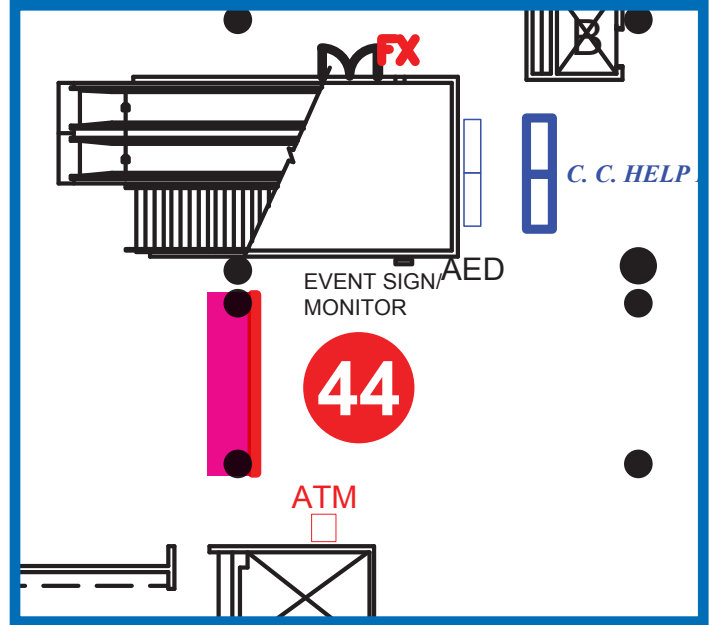

**Sponsorship Location Fee**  
\$4,500

**Printing & Installation Fee**  
\$2,798.16

### Wall Cling

25'9" W x 81.5" H

### Additional Info

Lobby B is the location of Commodity Classic registration, housing help desk, general info service desk, and association service desks. Lobby B is also the building entrance that thousands of attendees arriving by hotel shuttle will enter.

# HYATT REGENCY DENVER SIGNAGE & BRANDING OPPORTUNITIES



**DENVER** | MARCH 2-4, 2025  
COLORADO CONVENTION CENTER



DENVER | MARCH 2-4, 2025

HYATT REGENCY DENVER

## MAIN LOBBY ROUND COLUMN



**Location Fee:** \$2,400

**Printing & Installation (for 23' graphic):** \$7,596.54

**Printing & Installation (for 8' graphic):** \$2,184.14

**Total for 23' graphic:** \$9,996.54

**Total for 8' graphic:** \$4,584.14

*This column is in the main lobby near the hotel's Front Entrance and to the left of the Front Desk. Column wrap is 23' tall. There is also an option for a 8' graphic.*

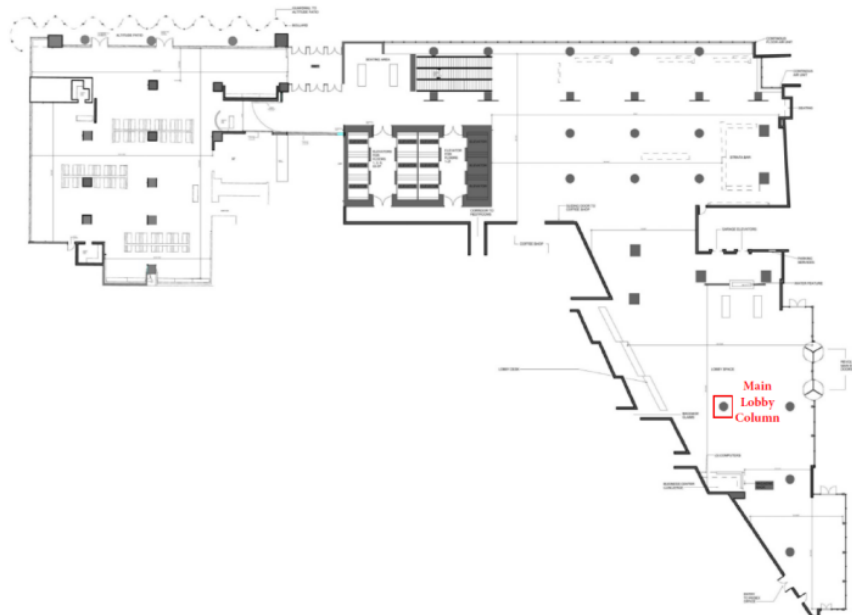

## MAIN LOBBY FLOOR CLING

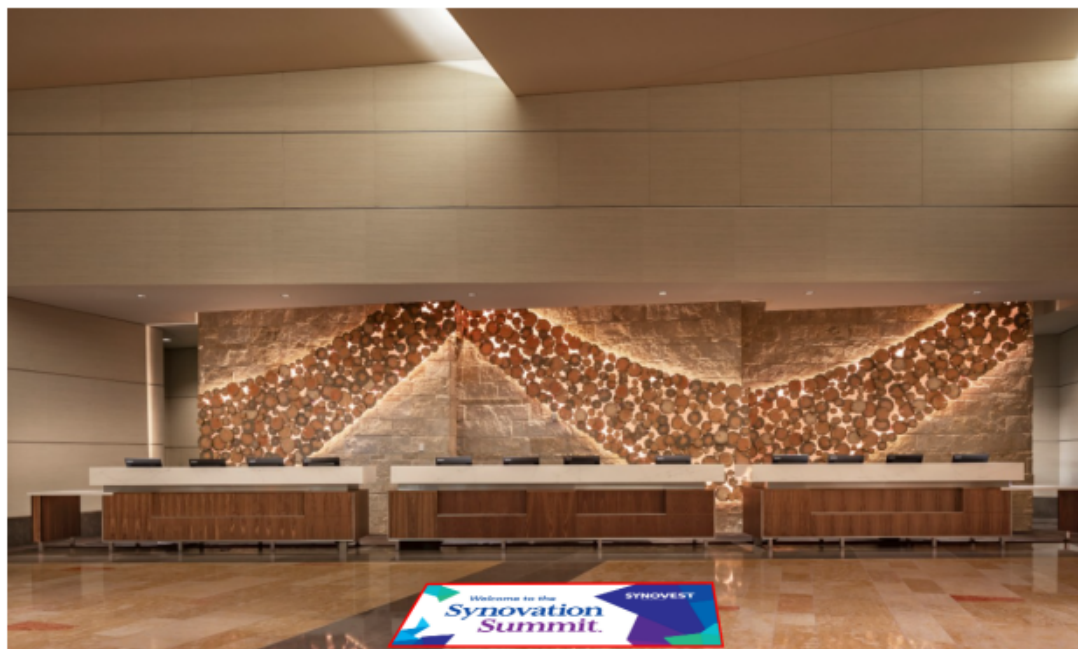

**Location Fee:** \$2,000

**Printing & Installation:**  
\$4,838.22

**Total:** \$6,838.22

*Floor Cling to be placed between the hotel's Front Entrance and the Front Desk in the Main Lobby. Pricing is based on a 12'x12' cling and includes contour cutting if needed.*

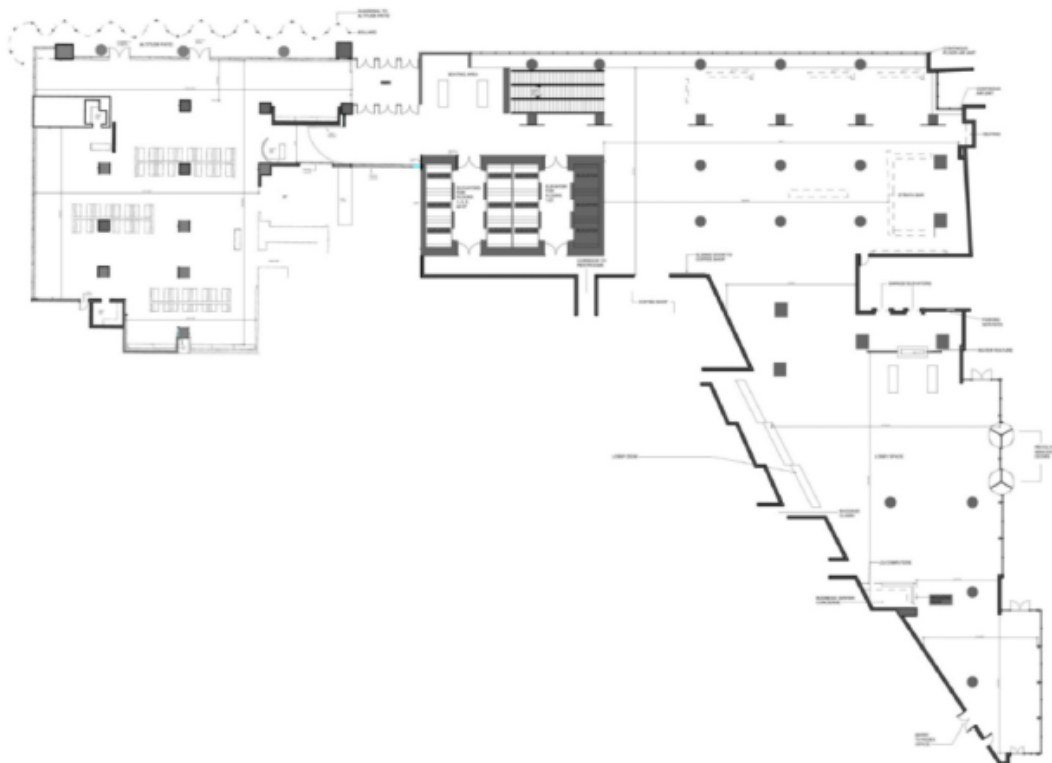



## ELEVATOR DOORS



### Location Fee:

3 Doors: \$9,000

6 Doors: \$18,000

12 Doors: \$36,000

### Printing & Installation:

3 Doors: \$2,594.80

6 Doors: \$3,767.05

12 Doors: \$7,534.10

**Total:** \$11,594.80 - \$43,534.10

*Hotel has a total of 12 elevators, a bank of 6 for high floors and a bank of 6 for lower floors.*

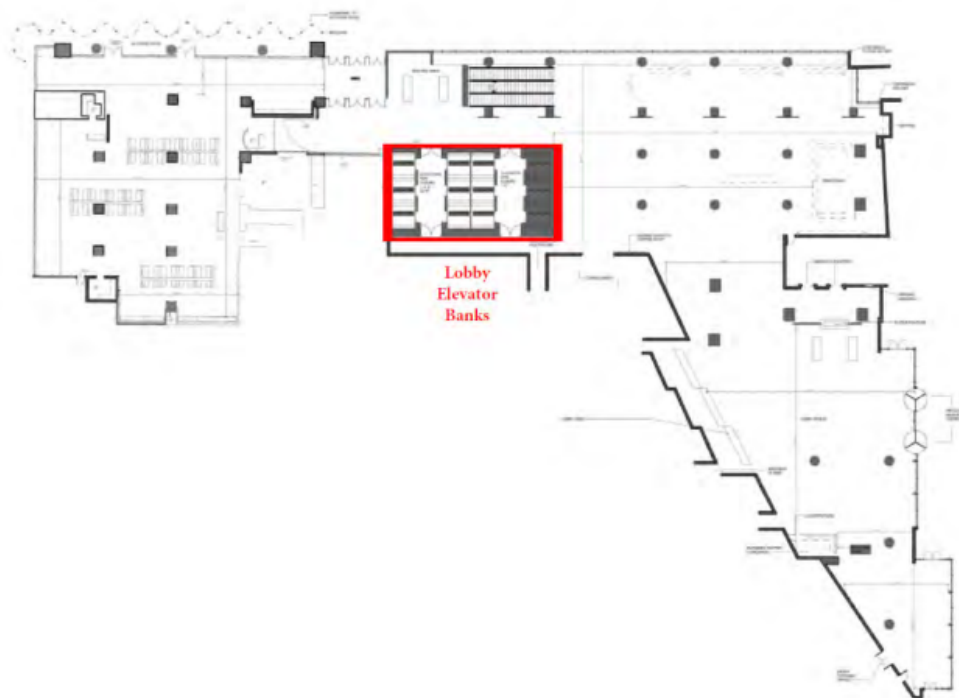

## ESCALATORS - LOBBY TO 3rd FLOOR



### **Metal Runners Only (2)**

**Location Fee:** \$7,000

**Printing & Installation:** \$3,134.34

**Total:** \$10,134.34

### **Glass Rails Only (6)**

**Location Fee:** \$7,000

**Printing & Installation:** \$21,980.52

**Total:** \$28,980.52

### **Metal Runners (2) and Glass Rails (2 outermost to frame the entire set of escalators)**

**Location Fee:** \$7,000

**Printing & Installation:** \$16,992.84

**Total:** \$23,992.84

*Escalators lead up to the start of all hotel meeting space. Graphics may be placed on metal runners, glass railings, or both.*

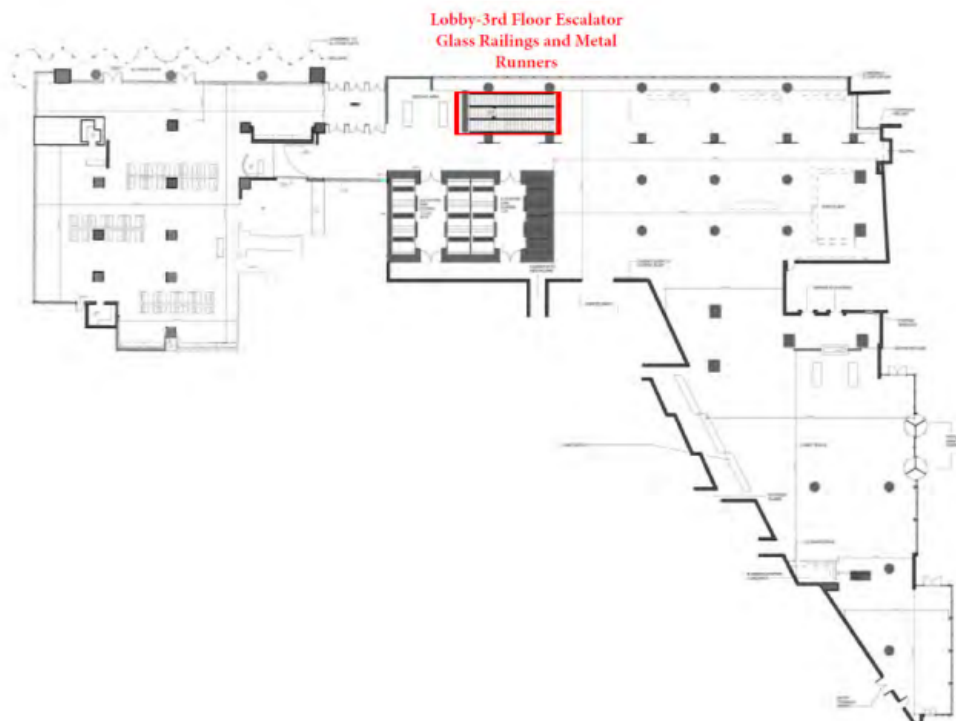

## WINDOWS BETWEEN LOBBY ESCALATORS AND ASSEMBLY LOUNGE



**Location Fee:** \$6,000

**Printing & Installation:**  
\$10,466.54

**Total:** \$16,466.54

- 6 windows are included (4 across x 4 down)
- Graphics are printed on semi-translucent material
- Graphics face in

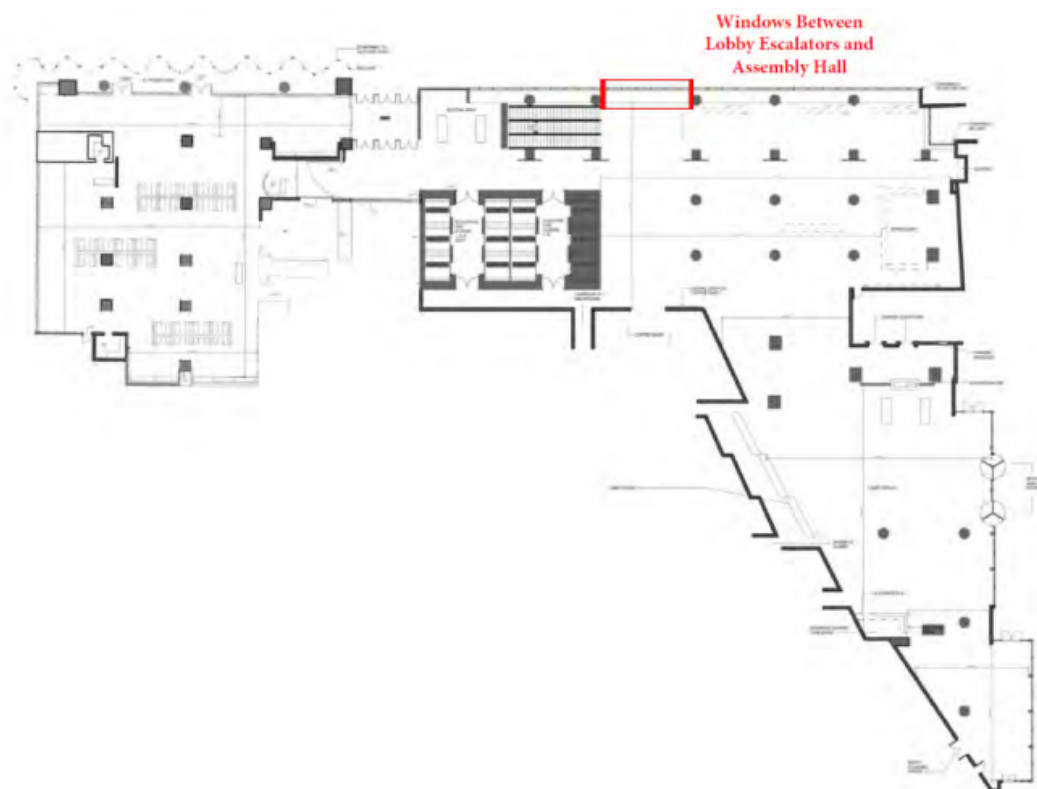

# CALIFORNIA STREET ENTRANCE PUSH DOORS



**Location Fee:** \$4,000

**Printing & Installation:** \$7,624.33

**Total: \$11,624.33**

- These doors will be the primary path to and from the convention center.
- Graphics applied to the outer "V" created by the handles on each set of doors.
- 4 sets of double-doors are included.
- Graphics are opaque and double-sided

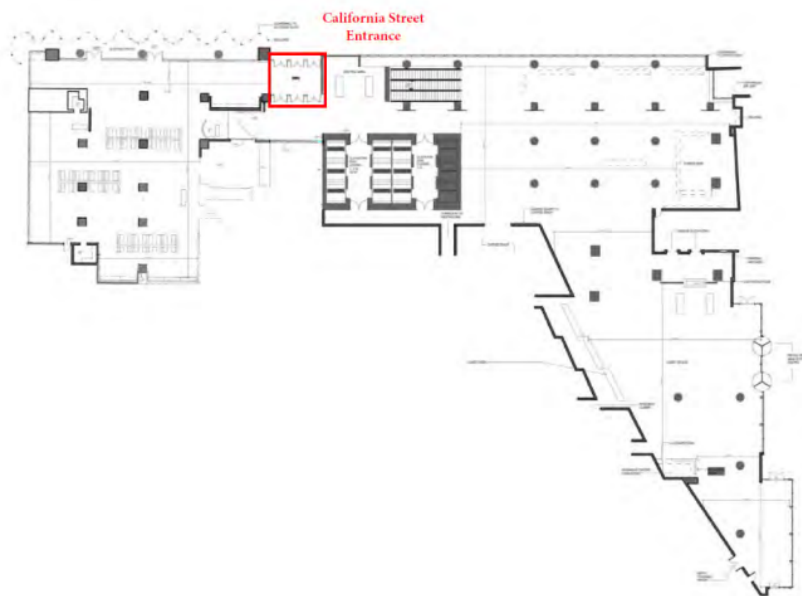



## HOTEL RESTAURANT

### "FORMER SAINT" WINDOWS



**Location Fee:** \$12,000

**Printing & Installation:** \$3,812.89

**Total: 15,812.89**

- Row of 6 windows on the California Street side of Former Saint, the hotel's restaurant
- Graphics face out and are visible from the street and those coming to and from the convention center
- Graphics are printed on semi-translucent adhesive

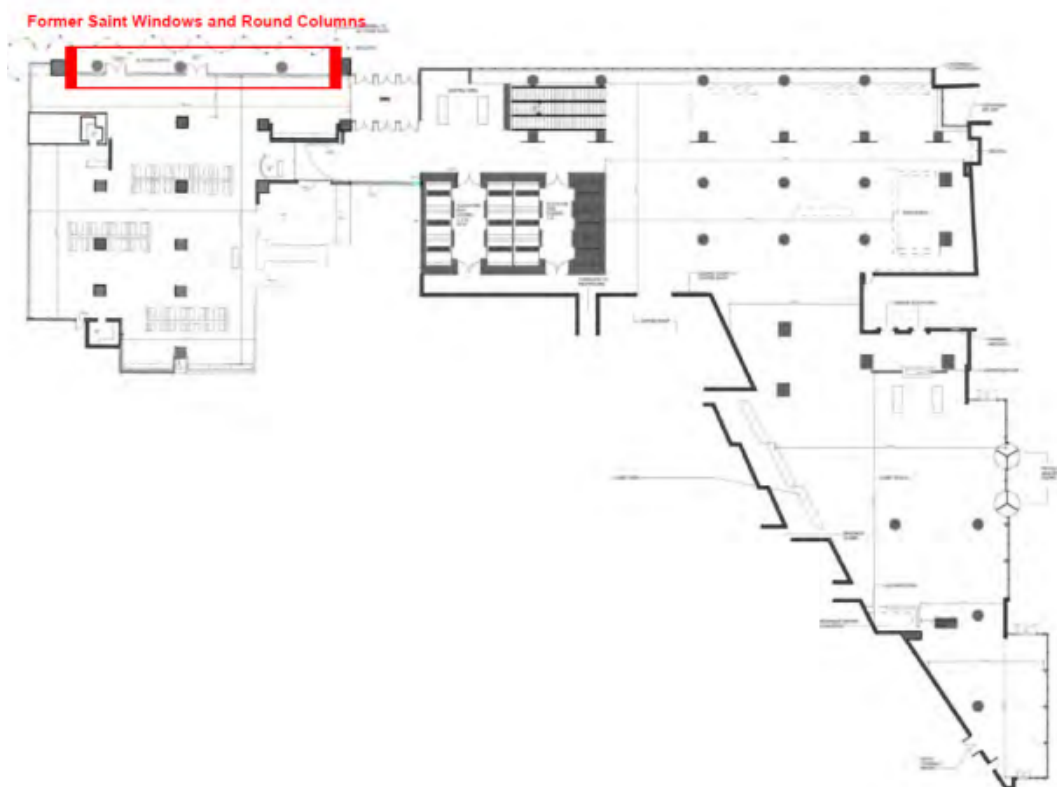



DENVER | MARCH 2-4, 2025

HYATT REGENCY DENVER

# HOTEL RESTAURANT "FORMER SAINT" EXTERIOR COLUMNS



**Location Fee:** \$12,000

**Printing & Installation:**  
\$9,557.01

**Total: \$21,557.01**

- Includes 3 round columns outside of Former Saint, the hotel's restaurant
- Branding to reach up to the light fixture on each column
- Graphics face the street and are visible to those going to and from the convention center

Former Saint Windows and Round Columns

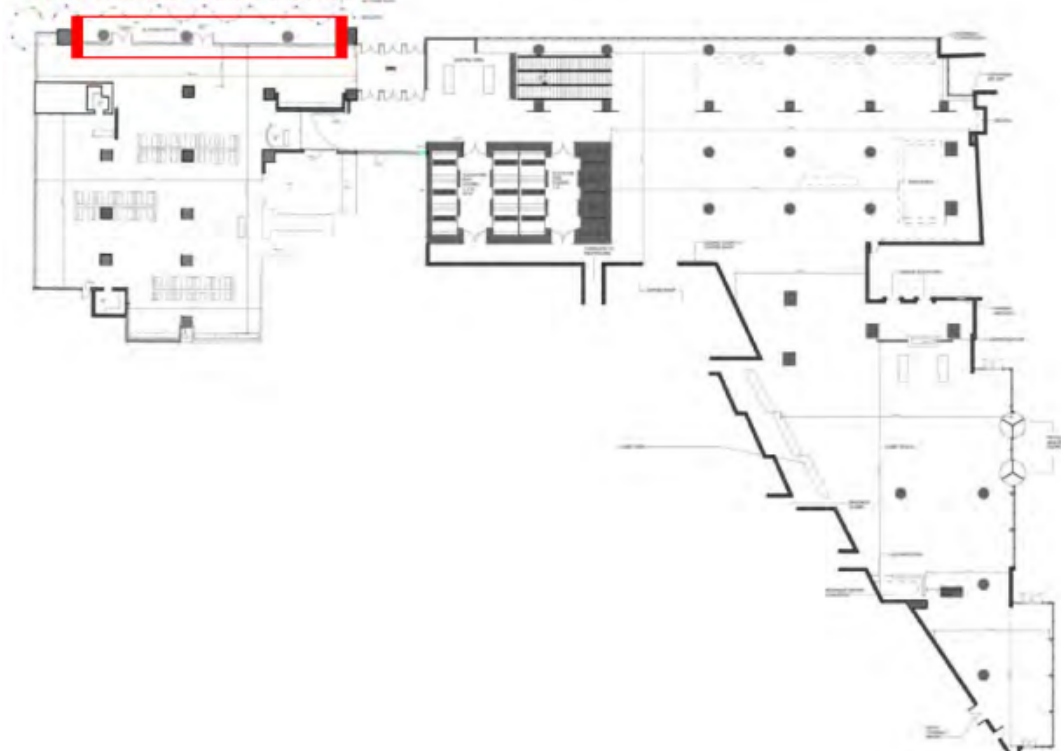

# EMBASSY SUITES SIGNAGE & BRANDING OPPORTUNITIES



**DENVER** | MARCH 2-4, 2025  
COLORADO CONVENTION CENTER

## Embassy Suites Entrance

OPPORTUNITY

#1



### Sponsorship Location Fee

\$5,000

### Printing & Installation Fee

\$2,175.36

### Window Clings

---

- A (x2) 38.125" W x 47.5" H
- B (x2) 38.125" W x 22.75" H
- C (x2) 34.25" W x 31" H
- D 32.5" W x 47.5" H
- E 32.5" W x 22.75" H
- F 32.5" W x 73" H
- G 32.5" W x 33" H

### Additional Info

---

Facing In

## Embassy Suites Elevator Doors

Ground Floor Lobby

OPPORTUNITY

#2



**Sponsorship Location Fee**  
\$5,000

**Printing & Installation Fee**  
\$2,387.08

### Elevator Clings

4 Elevators  
2 doors per elevator, each 21.25" W x 84.5" H

### Additional Info

Graphics to be applied to the outside of the elevator doors.

The Ground Floor Lobby is the entrance to the hotel. Guests must use these elevators to access the upper levels for the front desk, meeting space, and guest rooms.

## Embassy Suites Elevator Doors

Level 4/Main Lobby

OPPORTUNITY

#3



### Sponsorship Location Fee

\$5,000

### Printing & Installation Fee

\$2,387.08

### Elevator Clings

4 Elevators

2 doors per elevator, each 21.25" W x 84.5" H

### Additional Info

Graphics to be applied to the outside of the elevator doors.

Level 4 is the main lobby of the hotel. It is where the front desk, restaurant, and lounge are located. These elevators go to the meeting space, guest rooms, and the ground floor.

# HILTON DENVER SIGNAGE & BRANDING OPPORTUNITIES

Please contact Abby Podkul for more information:  
O: 314-754-1345 C: 314-517-5971  
[apodkul@soy.org](mailto:apodkul@soy.org)



**DENVER** | MARCH 2-4, 2025  
COLORADO CONVENTION CENTER